

TAPE AND REEL SPECIFICATIONS—SURFACE MOUNT

Tape and Reel Packing

Tape and reel packing is available for all SO, TSOT (thin SOT-23), SOT-23 3L/4L, SOT-223, SSOP, TSSOP, QFN, DFN and DD packages in accordance with EIA Specification 481-D with the following exceptions: **(DFN(DCB), TSOT and SC70 pin 1 is placed into quadrant 2. The pin 1 quadrant graphic “” is added onto the reel and pizza box labels. For square QFN as non-compliant to Figure 2 in the EIA-418 rev. D, but LTC will follow the Flow Chart for the Rules in Figure 3).**

Table 1 lists the applicable tape widths, dimensions and quantities for all LTC surface mount products. Consult a

sales office for tape and reel pricing and minimum order requirements. **Tape and reel packaging is ordered with a ‘#TRPBF’ suffix for lead free finish parts or a ‘#TR’ suffix for lead based finish parts.**

***Packages marked with an asterisk (*) below are available in 500 unit reels through designated sales channels. 500 unit reels are ordered with a ‘#TRMPBF’ or ‘#TRM’ suffix.**

****Tape Widths marked with a double asterisk (**) converted to 8mm width in July 2007.**

Table 1. Tape and Reel Specifications

LTC Package Code Designator	LTC Package Type	Number of Leads Offered	W Tape Width	P ₁ Component Pitch	P ₀ Hole Pitch	Reel Diameter	Units per Reel
DC*	DFN (2mm × 2mm)	3, 4, 6, 8	8/12mm**	4mm	4mm	180mm (7")	2,500*
DCB*	DFN (2mm × 3mm)	6, 8	8/12mm**	4mm	4mm	180mm (7")	2,500*
DD	DFN (3mm × 3mm)	8, 10, 12	12mm	8mm	4mm	330mm (13")	2,500
DDB*	DFN (3mm × 2mm)	8, 10, 12	8/12mm**	4mm	4mm	180mm (7")	2,500*
DE, UE	DFN (4mm × 3mm)	12, 14	12mm	8mm	4mm	330mm (13")	2,500
DF	DFN (4mm × 4mm)	12	12mm	8mm	4mm	330mm (13")	2,500
DH	DFN (5mm × 5mm)	16	12mm	8mm	4mm	330mm (13")	2,500
DHC	DFN (5mm × 3mm)	16	12mm	8mm	4mm	330mm (13")	2,500
DHD	DFN (5mm × 4mm)	16	12mm	8mm	4mm	330mm (13")	2,500
DJC	DFN (6mm × 3mm)	22	16mm	8mm	4mm	330mm (13")	2,500
DKD	DFN (7mm × 4mm)	24, 32	16mm	8mm	4mm	330mm (13")	2,500
F	TSSOP (4.4mm)	14, 20	16mm	8mm	4mm	330mm (13")	2,500
FE	TSSOP (4.4mm)	16, 20, 24	16mm	8mm	4mm	330mm (13")	2,500
FE	TSSOP (4.4mm)	28, 38	16mm	12mm	4mm	330mm (13")	2,000
FW	TSSOP (6.1mm)	48, 56	24mm	12mm	4mm	330mm (13")	1,800
G	SSOP (5.3mm)	16	16mm	12mm	4mm	330mm (13")	2,000
G	SSOP (5.3mm)	20, 24	16mm	12mm	4mm	330mm (13")	1,800
G	SSOP (5.3mm)	28, 36, 44, 48	24mm	12mm	4mm	330mm (13")	2,000
GN	SSOP (0.150)	16	12mm	8mm	4mm	330mm (13")	2,500
GN	SSOP (0.150)	20, 24, 28	16mm	8mm	4mm	330mm (13")	2,500
GW	SSOP (7.62mm)	36, 44	24mm	12mm	4mm	330mm (13")	1,000
KC	UTDFN (2mm × 2mm)	8	8mm	8mm	4mm	180mm (7")	2,500
KD	UTDFN (3mm × 3mm)	10	12mm	8mm	4mm	330mm (13")	2,500
KE	UTDFN (4mm × 3mm)	14	12mm	8mm	4mm	330mm (13")	2,500
M, Q, R	DD	3, 5 or 7	24mm	16mm	4mm	330mm (13")	750
MS8, MS8E	MSOP (0.118)	8	12mm	8mm	4mm	330mm (13")	2,500

TAPE AND REEL

TAPE AND REEL SPECIFICATIONS—SURFACE MOUNT

Table 1. Tape and Reel Specifications (cont)

LTC Package Code Designator	LTC Package Type	Number of Leads Offered	W Tape Width	P ₁ Component Pitch	P ₀ Hole Pitch	Reel Diameter	Units per Reel
MS, MSE	MSOP (0.118)	10, 12, 16	12mm	8mm	4mm	330mm (13")	2,500
PD	UTQFN (3mm × 3mm)	16	12mm	8mm	4mm	330mm (13")	2,500
PDC	UTQFN (3mm × 4mm)	20	12mm	8mm	4mm	330mm (13")	2,500
PF	UTQFN (4mm × 4mm)	24, 28	12mm	8mm	4mm	330mm (13")	2,500
S8, S8E	SO (0.150)	8	12mm	8mm	4mm	330mm (13")	2,500
S	SO (0.150)	14	16mm	8mm	4mm	330mm (13")	2,500
S	SO (0.150)	16	16mm	8mm	4mm	330mm (13")	2,500
ST	SOT-223	3	16mm	12mm	4mm	330mm (13")	2,000
SW	SO (0.300)	16	16mm	12mm	4mm	330mm (13")	1,000
SW	SO (0.300)	18	24mm	12mm	4mm	330mm (13")	1,000
SW	SO (0.300)	20	24mm	12mm	4mm	330mm (13")	1,000
SW	SO (0.300)	24	24mm	12mm	4mm	330mm (13")	1,000
SW	SO (0.300)	28	24mm	12mm	4mm	330mm (13")	1,000
S3*	SOT-23	3	8mm	4mm	4mm	180mm (7")	2,500*
S5*	SOT-23, TSOT	5	8mm	4mm	4mm	180mm (7")	2,500*
S6*	SOT-23, TSOT	6	8mm	4mm	4mm	180mm (7")	2,500*
SC6*	SC70	6	8mm	4mm	4mm	180mm (7")	2,500*
SC8*	SC70	8	8mm	4mm	4mm	180mm (7")	2,500*
TS8*	TSOT	8	8mm	4mm	4mm	180mm (7")	2,500*
UDB*	QFN (3mm × 2mm)	10, 12	8mm	4mm	4mm	180mm (7")	2,500*
UD	QFN (3mm × 3mm)	16, 20	12mm	8mm	4mm	330mm (13")	2,500
UDC	QFN (3mm × 4mm)	18, 20, 24	12mm	8mm	4mm	330mm (13")	2,500
UDD	QFN (3mm × 5mm)	24	12mm	8mm	4mm	330mm (13")	2,500
UDE	QFN (3mm × 6mm)	28	16mm	8mm	4mm	330mm (13")	2,500
UF	QFN (4mm × 4mm)	16, 20, 24, 28	12mm	8mm	4mm	330mm (13")	2,500
UFD	QFN (4mm × 5mm)	20, 24, 28	12mm	8mm	4mm	330mm (13")	2,500
UFE	QFN (4mm × 6mm)	26, 32, 38	16mm	8mm	4mm	330mm (13")	2,500
UFF	QFN (4mm × 7mm)	34, 36, 44	16mm	8mm	4mm	330mm (13")	2,500
UH	QFN (5mm × 5mm)	20, 24, 32, 40	12mm	8mm	4mm	330mm (13")	2,500
UHE	QFN (5mm × 6mm)	28, 36, 42	16mm	8mm	4mm	330mm (13")	2,500
UHF	QFN (5mm × 7mm)	38	16mm	8mm	4mm	330mm (13")	2,500
UHG	QFN (5mm × 8mm)	39, 40, 52	16mm	8mm	4mm	330mm (13")	2,500
UHH	QFN (5mm × 9mm)	48, 56, 58	16mm	8mm	4mm	330mm (13")	2,500
UJ	QFN (6mm × 6mm)	40	16mm	12mm	4mm	330mm (13")	2,000
UK	QFN (7mm × 7mm)	44, 48	16mm	12mm	4mm	330mm (13")	2,000
UKG	QFN (7mm × 8mm)	47, 52	16mm	12mm	4mm	330mm (13")	2,000
UKH	QFN (7mm × 9mm)	64	16mm	12mm	4mm	330mm (13")	2,000
UKJ	QFN (7mm × 11mm)	64	24mm	12mm	4mm	330mm (13")	2,000
UKK	QFN (7mm × 12mm)	68	24mm	12mm	4mm	330mm (13")	2,000
UP	QFN (9mm × 9mm)	64	16mm	12mm	4mm	330mm (13")	2,000
WKG	QFN (7mm × 8mm)	52	16mm	12mm	4mm	330mm (13")	2,000
WP	QFN (9mm × 9mm)	64	16mm	12mm	4mm	330mm (13")	2,000

TAPE AND REEL SPECIFICATIONS—SURFACE MOUNT

Bending Radius

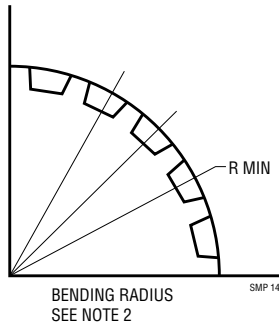

Embossed Carrier Dimensions (8mm, 12mm, 16mm, 24mm Tape Only)

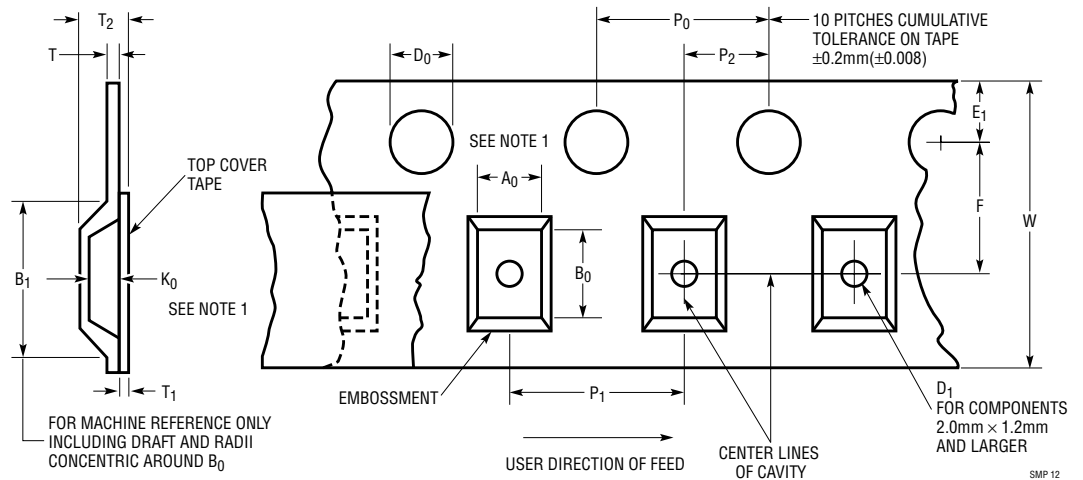

Embossed Tape—Constant Dimensions

Tape Width	D_0	E_1	P_0	P_2	T Max	T_1 Max	$A_0 B_0 k_0$
8mm	1.5	+0.10	4.0 ± 0.10	2.0 ± 0.05	0.600	0.10	See Note 1
12mm		-0.0	(0.069 ± 0.004)	(0.079 ± 0.002)	(0.024)	(0.004)	
16mm	(0.059)	+0.004					
24mm		-0.0					

Embossed Tape Variable Dimensions

Tape Width	B_1 Max	D_1 Min	F	T_2 Max	R Min	W Max
8mm	4.35 (0.171)	1.0 (0.039)	3.5 ± 0.05	2.5 (0.098)	25 0.984	8.3
12mm (0.323)	8.2 (0.059)	1.5 (0.217 ±0.002)	5.5 ± 0.05 (0.256)	6.5 (0.256)	30 (1.181)	12.3
16mm	12.1 (0.476)	1.5 (0.217 ±0.002)	7.5 ± 0.10 (0.295 ±0.004)	8.0 (0.315)	40 (1.575)	16.3
24mm	20.1 (0.791)	1.5 (0.217 ±0.002)	11.5 ± 0.10 (0.453 ±0.004)	12.0 (0.472)	50 (1.969)	24.3

Note 1: The cavity defined by A_0 , B_0 and K_0 shall surround the component with sufficient clearance that:

- a) the component does not protrude above the top surface of the carrier tape.
- b) the component can be removed from the cavity in a vertical direction without mechanical restriction after the top cover tape has been removed.

- c) rotation of the component is limited to 20° maximum for 8mm and 12mm tapes and 10° maximum for 16mm and 24mm tapes.
- d) lateral movement of the component is restricted to 0.5mm maximum for 8mm and 12mm wide tape and to 1.0mm maximum for 16mm and 24mm wide tape.

Note 2: The tape with or without components shall pass around R without damage.

TAPE AND REEL SPECIFICATIONS—SURFACE MOUNT

Component Rotation

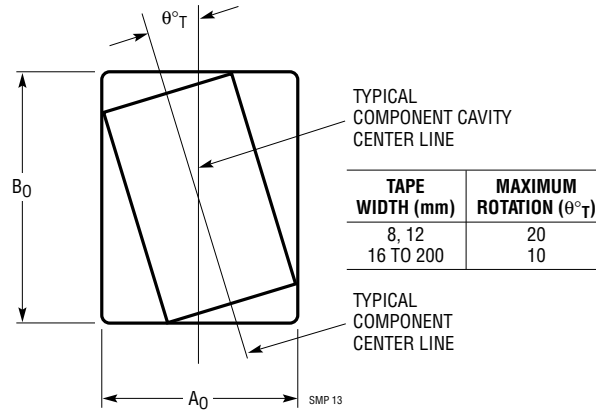

Tape Camber (Top View)

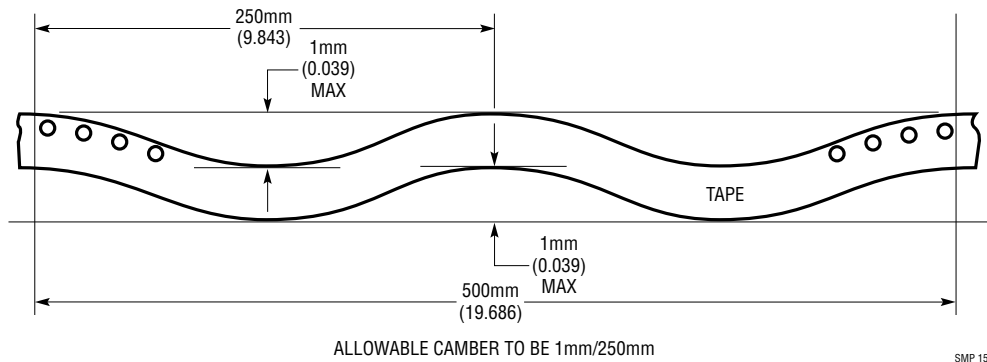

Tape Leader (Start/End) Specification

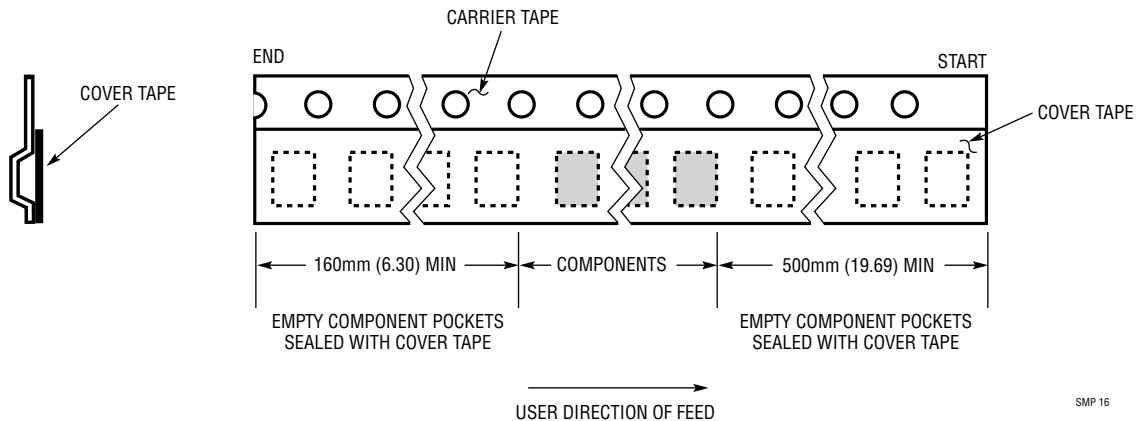

TAPE AND REEL SPECIFICATIONS—SURFACE MOUNT

S3
SOT-23 Devices

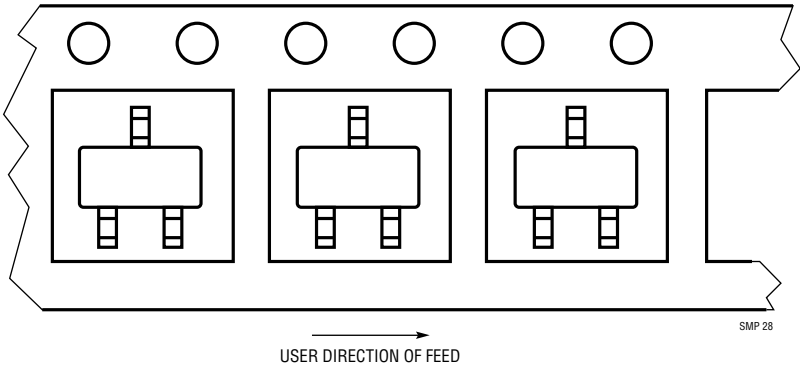

S5
TSOT, SOT-23 Devices

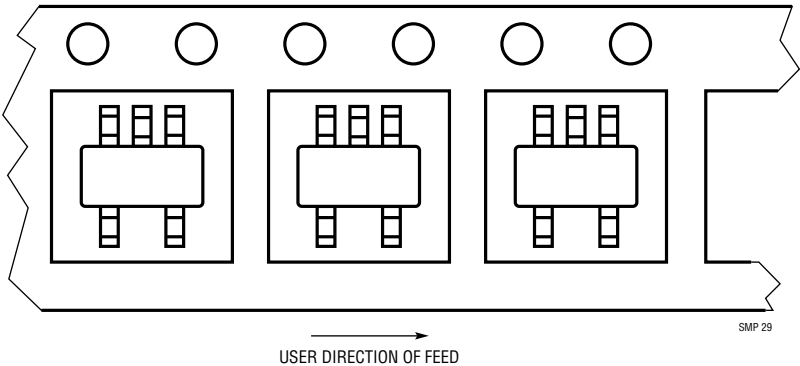

SC6, S6 and TS8
SC70, TSOT, SOT-23, DFN (DCB) Devices

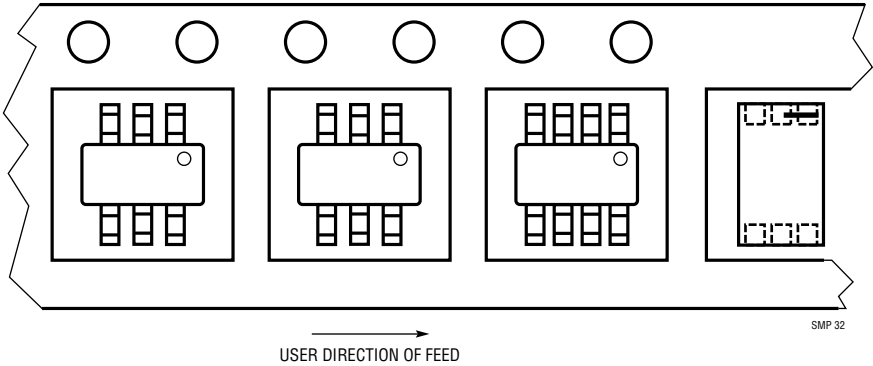

TAPE AND REEL SPECIFICATIONS—SURFACE MOUNT

**ST
SOT-223 Devices**

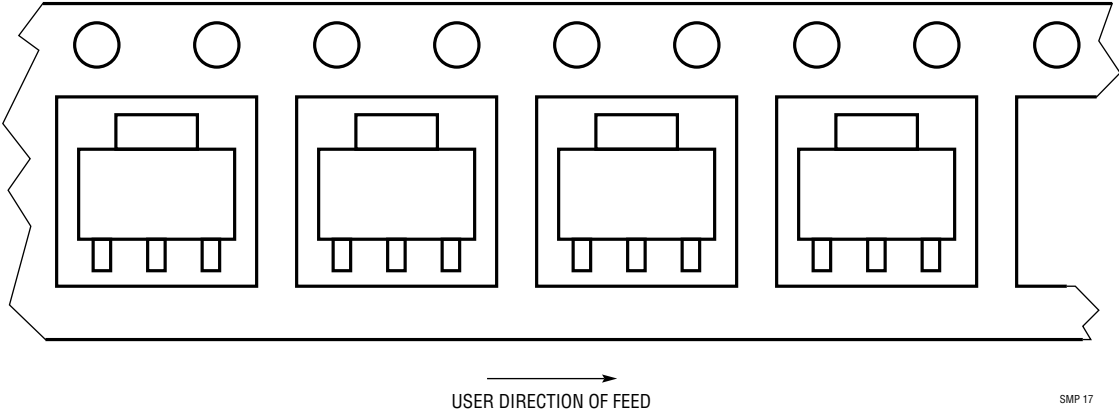

**M, Q, R
DD Pak Devices**

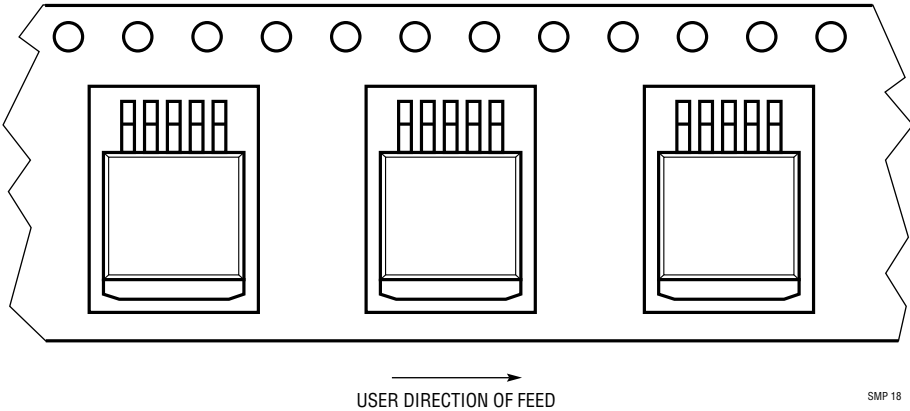

**F, FE, FW, G, GN, GW, S8, S, SW, MS8, MS, MS8E, MSE,
SSOP, TSSOP, QFN, DFN, UTDFN and UTQFN Devices [except DFN (DCB)]**

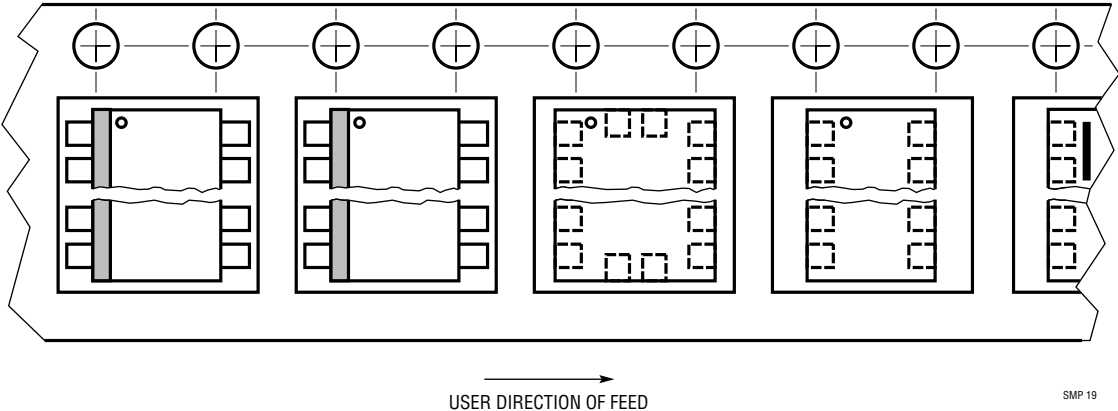

REEL DIMENSIONS—SURFACE MOUNT

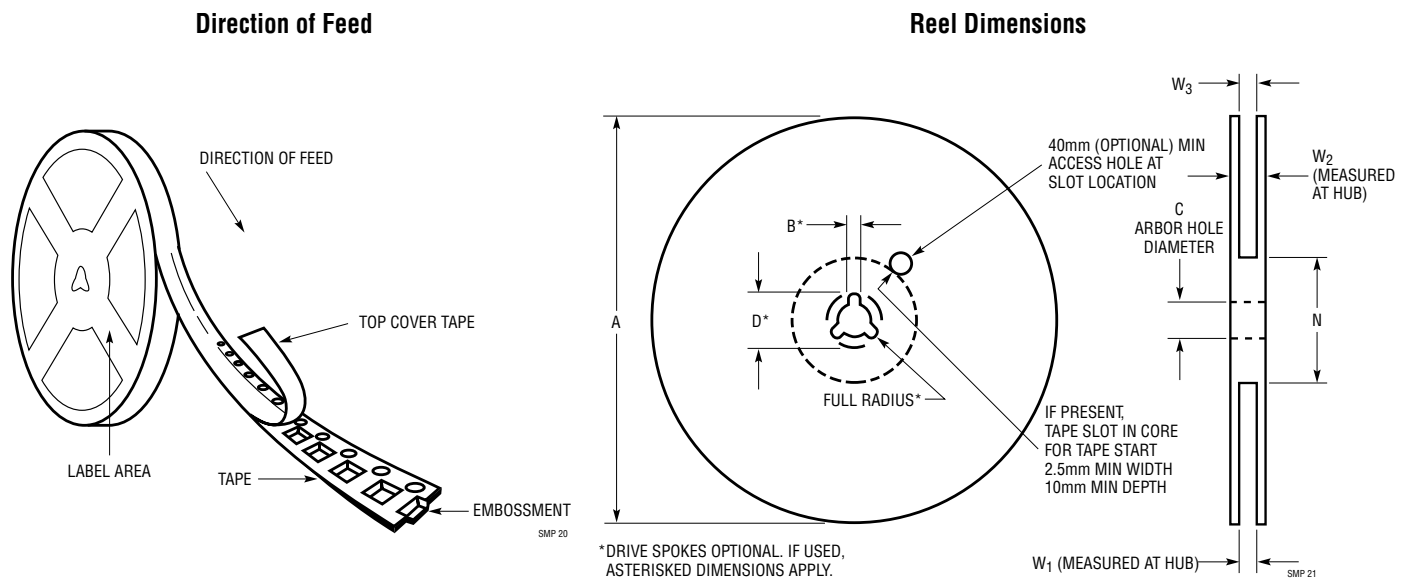

Tape Width	A Max	B Min	C	D* Min	N Min	W ₁	W ₂ Max	W ₃
8mm	180	1.5	13.0 ^{+0.5} _{-0.2}	20.2	60	8.4 ^{+1.5} _{-0.0}	14.4	Shall Accommodate Tape Width Without Interference
	330	1.5	13.0 ^{+0.5} _{-0.2}	20.2	50	8.4 ^{+1.5} _{-0.0}	14.4	
12mm	180	1.5	13.0 ^{+0.5} _{-0.2}	20.2	60	12.4 ^{+2.0} _{-0.0}	18.4	
	330	1.5	13.0 ^{+0.5} _{-0.2}	20.2	50	12.4 ^{+2.0} _{-0.0}	18.4	
16mm	330	1.5	13.0 ^{+0.5} _{-0.2}	20.2	50	16.4 ^{+2.0} _{-0.00}	22.4	
24mm	330	1.5	13.0 ^{+0.5} _{-0.2}	20.2	60	24.4 ^{+2.0} _{-0.00}	30.4	

Note 1: All dimensions in millimeters.

Note 2: See Table 1 for tape width and reel diameter of specific packages.

TAPE AND REEL SPECIFICATIONS—TO-92

TO-92 Tape Dimension

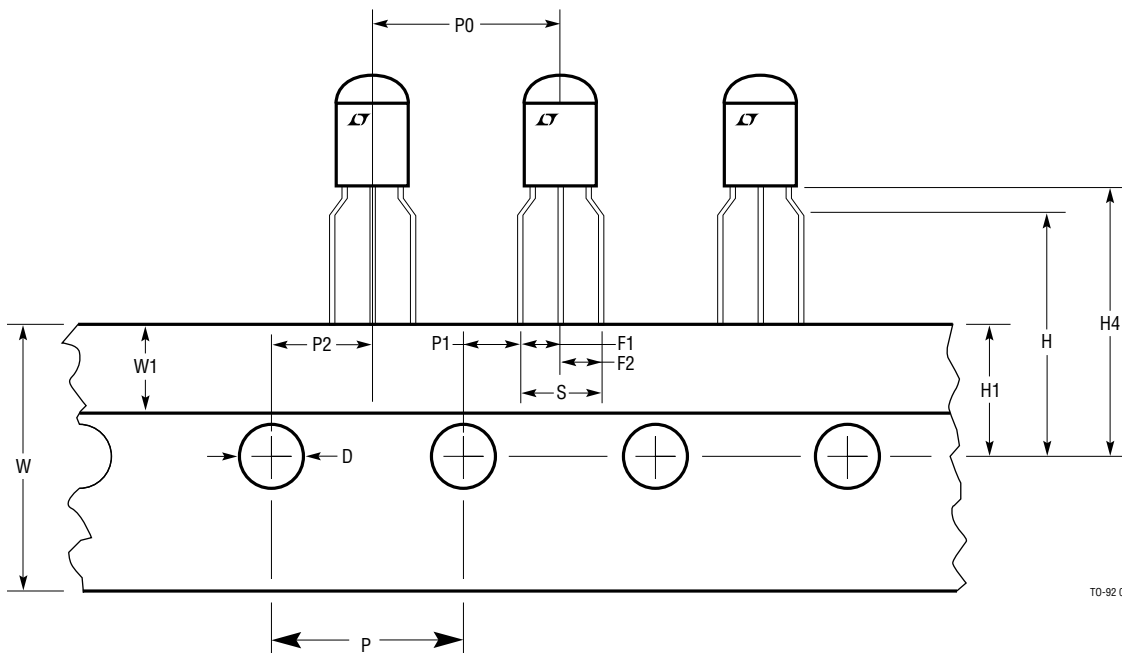

TO-92 01

TO-92 Reel Dimensions

Table 1

Symbol	Description	Dimension (mm)
D	Sprocket Hole Diameter	4 ± 0.2
H	Length from Seating Plane	16 ± 0.5
H1	Sprocket Hole Location	9 ± 0.5
H4	Component Base Height	20 Max
P	Sprocket Hole Pitch	12.7 ± 0.2
P0	Pitch of Component	12.7 ± 0.5
P1	Lead Location	3.85 ± 0.5
P2	Center of Seating Plane Location	6.35 ± 0.4
S	Component Lead Spacing	5 +0.8/-0.2
W	Carrier Tape Width	18 +1, -0.5
W1	Adhesive Tape Width	6.0 ± 1.0
F1, F2	Lead-to-Lead Distance	2.5 +0.4, -0.1

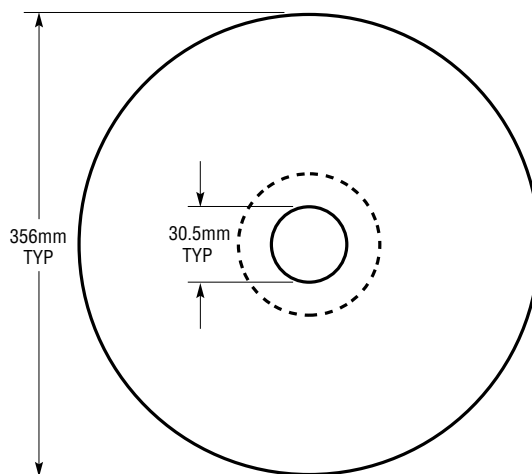

TO-92 02

TAPE AND REEL SPECIFICATIONS—TO-92

Reel Pak Tape Orientation on Reel

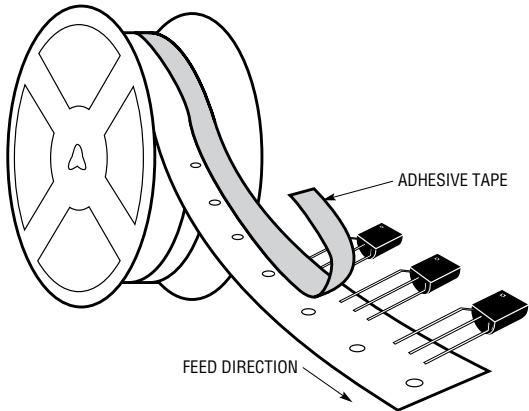

TO-92 03

Ammo Pak Tape Orientation Inside Box

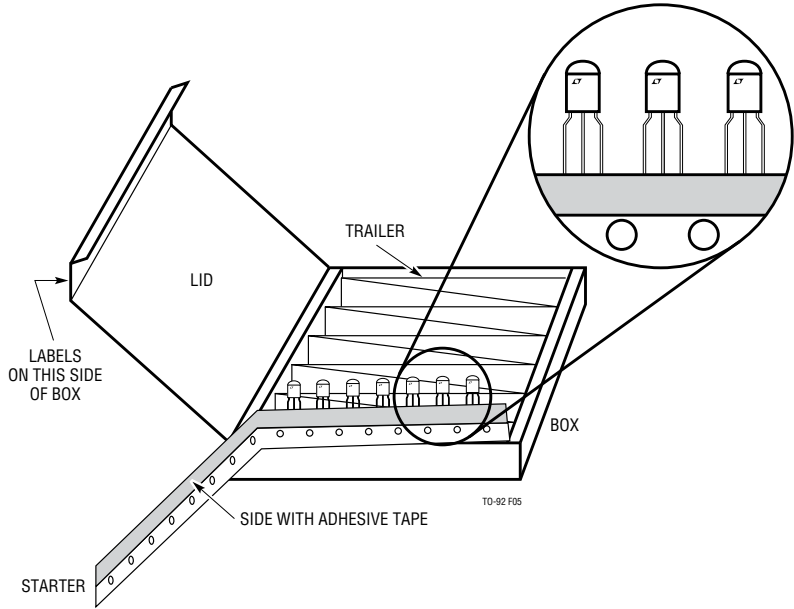

TO-92 F05

Package Orientation on Tape

STYLE E: Standard Flow TR
(Flat Side of Package Faces Toward the Adhesive Tape)

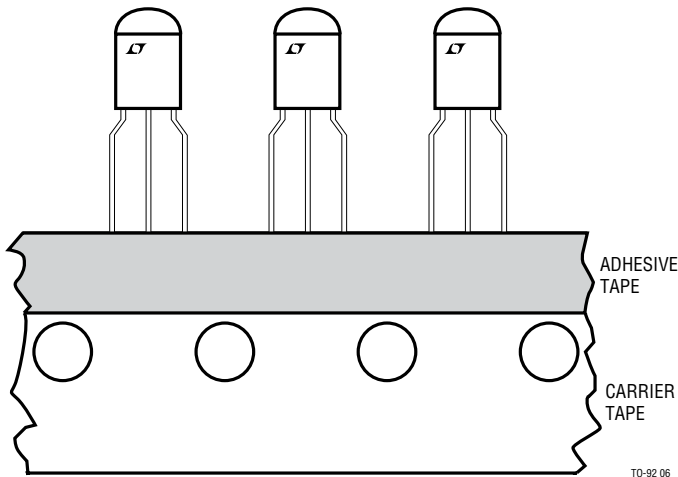

TO-92 06

STYLE A: Special Flow TRA
(Rounded Side of Package Faces Toward the Adhesive Tape)

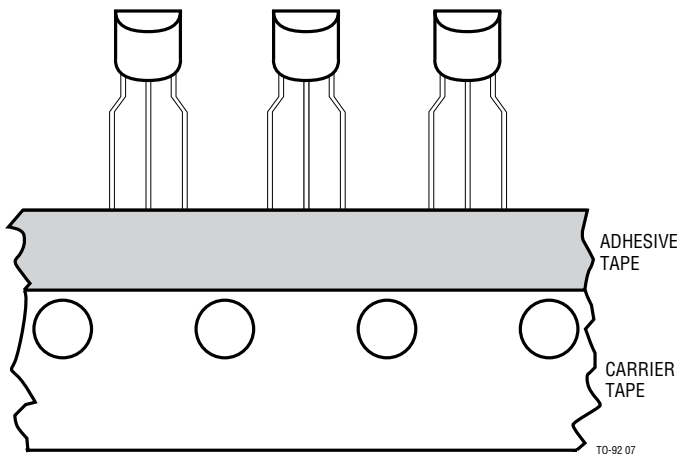

TO-92 07