

REV	DESCRIPTION	DATE	APPROVED
00	INITIAL COMPOSITE DRAWING	8/7/07	MD

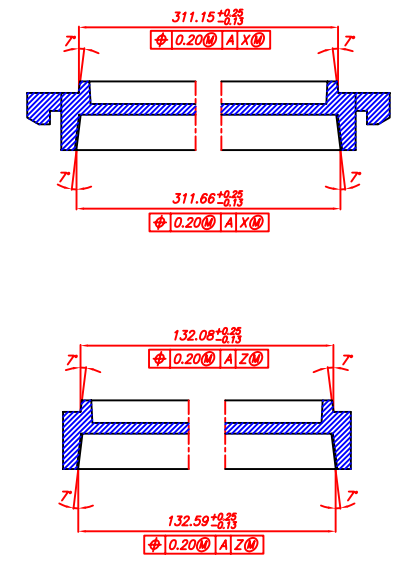

TRAY STACKING DETAIL
(SCALE:4/1)

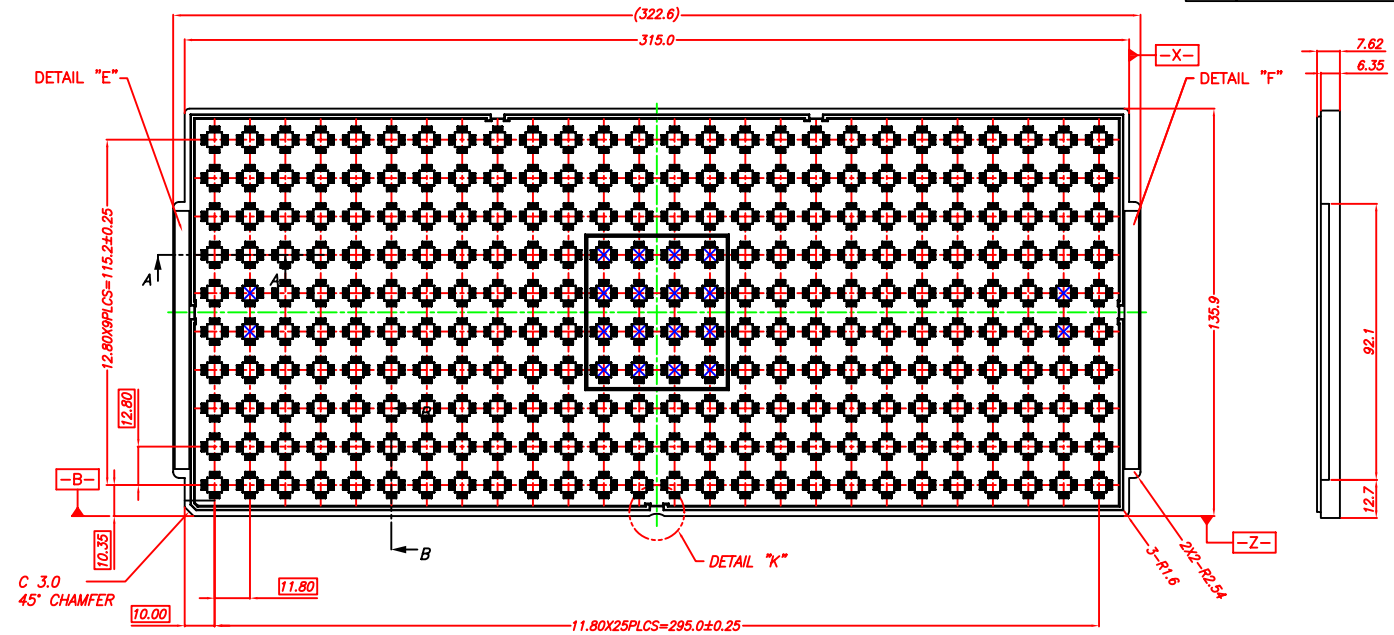
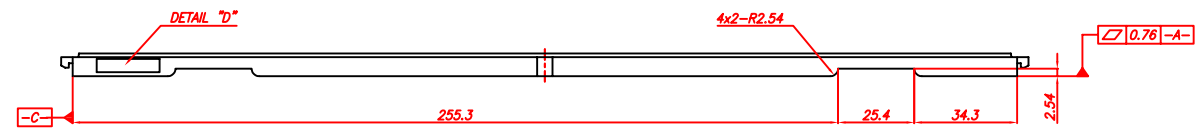

LGA 6.25mm x 6.25mm
KS - 870200 REV.00

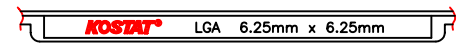

DETAIL "E"
(SCALE:2/1)

DETAIL "D"
(SCALE:2/1)



DATE DETAIL
(SCALE:2/1)



DETAIL "F"
(SCALE:2/1)

LINEAR
TECHNOLOGY
1630 McCarthy Blvd.
Milpitas, CA 95035
Phone: 408-432-1900
LTC Confidential

PIECE PART DRAWING
SIP 6.25MMX6.25MM
BLACK TRAY

DRAWING NO.
50-8040 REV0

APPROVALS
DRAWN: M.OTHEND / D.PRUITT
CHECKED: R.RANGANATHAN

TOLERANCES UNLESS OTHERWISE SPECIFIED:
FRACTIONS N/A
DECIMALS 0.001 ± 0.003
ANGLES *1
SCALE N/A
SIZE N/A
SHEET 1 OF 4

REV	DESCRIPTION	DATE	APPROVED
00	INITIAL COMPOSITE DRAWING	8/7/07	MD

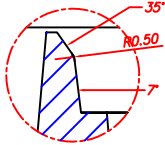

DETAIL "G"
(SCALE:12/1)

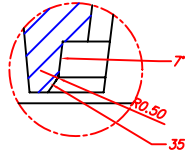

DETAIL "H"
(SCALE:12/1)

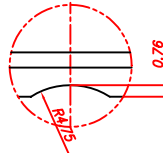

DETAIL "K"
(SCALE:4/1)

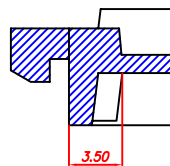

SLIP LOCK DETAIL
(SCALE:5/1)

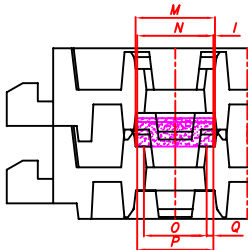
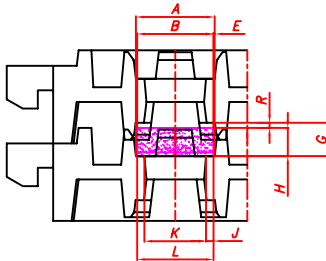
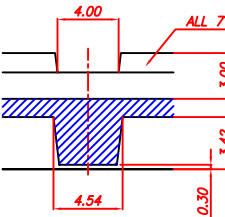

SIMULATION CRITERIA						
1.	A > B	PACKAGE NESTING				
2.	E > O	PACKAGE LATERAL PLAY				
3.	G > H	PACKAGE VERTICAL PLAY				
4.	I > O	PACKAGE LATERAL PLAY AT FLIPPED				
5.	K < L	PACKAGE SEATING				
6.	J > O	PACKAGE SEATING PLAY				
7.	M > N	PACKAGE NESTING AT FLIPPED				
8.	O < P	PACKAGE SEATING AT FLIPPED				
9.	Q > O	PACKAGE SEATING PLAY AT FLIPPED				
No.	Section "M" Condition	Nominal	Max. TRAY Min. PKG	Min. TRAY Max. PKG	Results	
1	Tray A	6.450	6.530	6.370	Pass	
	Pkg. B	6.250	6.150	6.350	Pass	
2	Gap. E (A-B)/2	0.100	0.190	0.010	Pass	
3	Tray G	2.730	2.860	2.600	Pass	
	Pkg. H	2.320	2.220	2.420	Pass	
4	Gap. R (G-H)	0.410	0.640	0.180	Pass	
5	Cap. I (M-N)/2	0.125	0.215	0.035	Pass	
6	Tray K	5.050	5.180	4.920	Pass	
	Pkg. L	6.250	6.150	6.350	Pass	
7	Gap. J (K-L)/2	0.600	0.485	0.715	Pass	
8	Tray M	6.500	6.580	6.420	Pass	
	Pkg. N	6.250	6.150	6.350	Pass	
9	Tray O	5.130	5.260	5.000	Pass	
	Pkg. P	6.250	6.150	6.350	Pass	
10	Cap. Q (P-O)/2	0.560	0.445	0.675	Pass	

LINEAR TECHNOLOGY
 1630 McCarthy Blvd.
 Milpitas, CA, 95035
 Phone: 408-432-1900
 LTC Confidential

PIECE PART DRAWING
 SIP 6.25MMX6.25MM
 BLACK TRAY

DRAWING NO.
 50-8040 REV0

APPROVALS
 DRAWN: M.OTHEND / D.PRUITT
 CHECKED: R.RANGANATHAN

DATE:

TOLERANCES UNLESS OTHERWISE SPECIFIED:
 FRACTIONS N/A DECIMALS 0.001 = ± 0.001 ANGLES ± 1
 SCALE N/A SIZE N/A SHEET 2 OF 4

REV	DESCRIPTION	DATE	APPROVED
00	INITIAL COMPOSITE DRAWING	8/7/07	MD

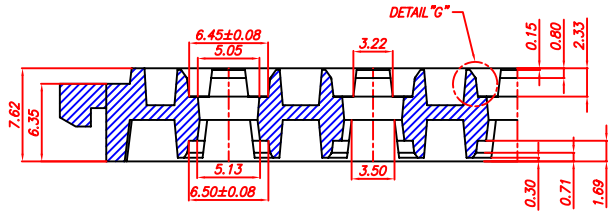

SECTION "A-A"
(SCALE:4/1)

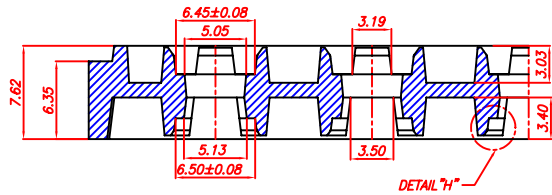

SECTION "B-B"
(SCALE:4/1)

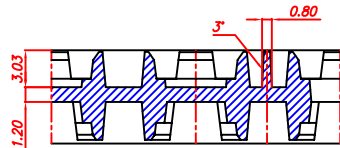

VACUUM CELL
(SCALE:4/1)

LINEAR
TECHNOLOGY
1630 McCarthy Blvd.
Milpitas, CA, 95035
Phone: 408-432-1900
LTC Confidential

PIECE PART DRAWING
SIP 6.25MMX6.25MM
BLACK TRAY

DRAWING NO.

50-8040 REV0

APPROVALS

DATE:

DRAWN:
M.OTHIEHD / D.PRUITT

TOLERANCES UNLESS OTHERWISE SPECIFIED:

FRACTIONS
N/A

DECIMALS
XXXX = ± 0.05
XXXXX = ± 0.013

ANGLES
± 1

CHECKED:
R.RANGANATHAN

SCALE
N/A

SIZE
N/A

SHEET
3 OF 4

REV	DESCRIPTION	DATE	APPROVED
00	INITIAL COMPOSITE DRAWING	8/7/07	MD

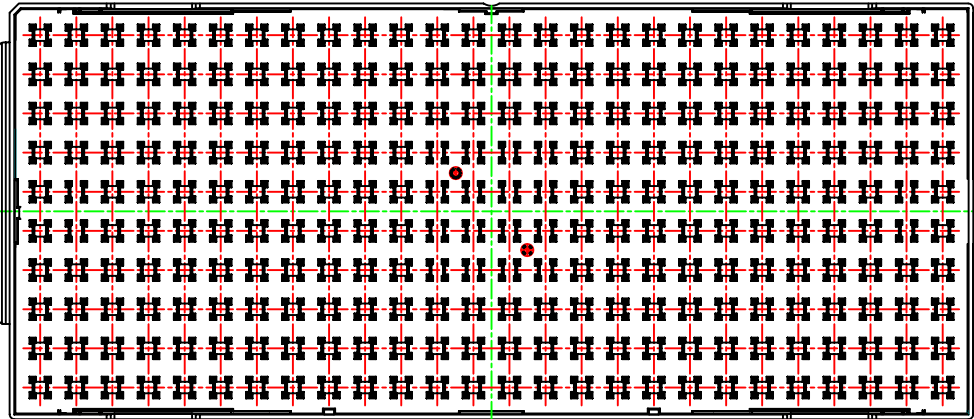

BOTTOM VIEW
(SCALE:1/1)

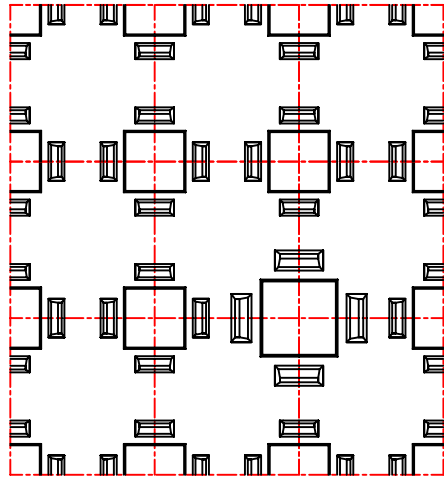

TOP VIEW
(SCALE:4/1)

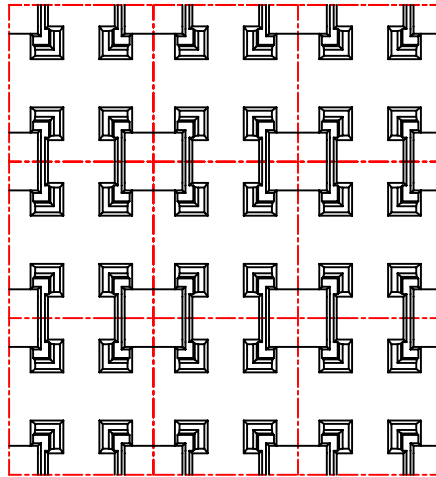

BOTTOM VIEW
(SCALE:4/1)

LINEAR
TECHNOLOGY
1630 McCarthy Blvd.
Milpitas, CA, 95035
Phone: 408-432-1900
LTC Confidential

PIECE PART DRAWING
SIP 6.25MMX6.25MM
BLACK TRAY

DRAWING NO.

50-8040 REV0

APPROVALS	DATE:
DRAWN: M.OTHEND / D.PRUITT	
CHECKED: R.RANGANATHAN	

TOLERANCES UNLESS OTHERWISE SPECIFIED:

FRACTIONS
N/A

DECIMALS
XXXX = 2 0.05
XXXXX = 2 0.025

ANGLES
± 1

SCALE
N/A

SIZE
N/A

SHEET
4 OF 4