

REV	DESCRIPTION	DATE	APPROVED
A	COMPOSITE DRAWING	10/03/07	MD

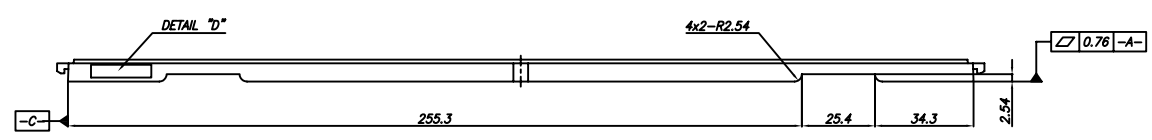

9mm x 15mm Module
KS - 870190

DETAIL "D"
(SCALE:2/1)

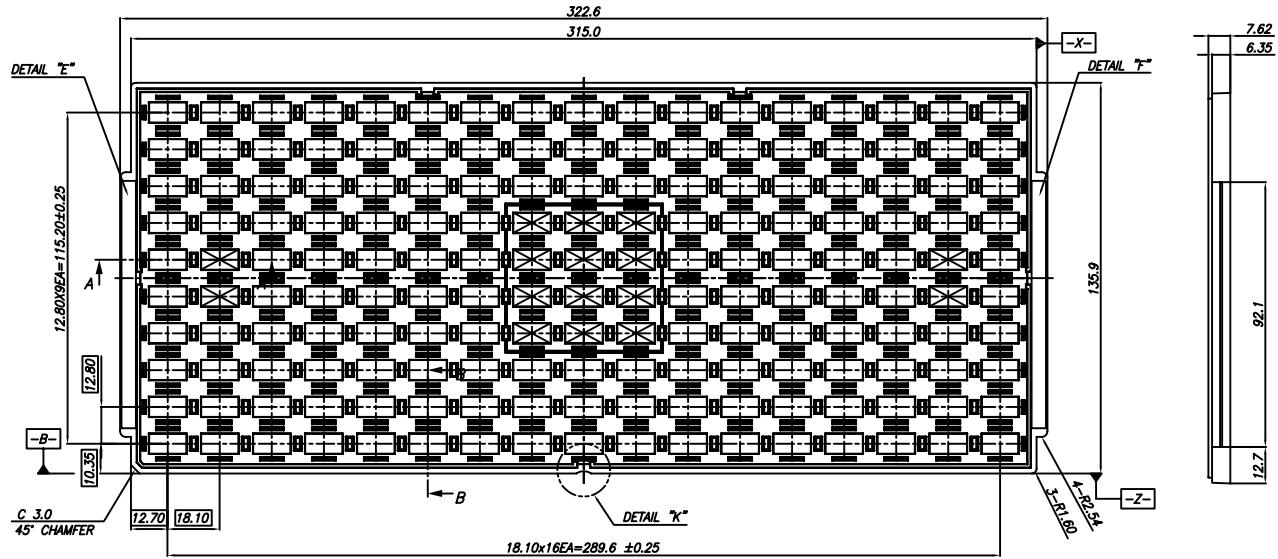

DATE DETAIL
(SCALE:2/1)

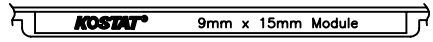

DETAIL "E"
(SCALE:2/1)



DETAIL "F"
(SCALE:2/1)

LINEAR TECHNOLOGY
1630 McCarthy Blvd.
Milpitas, CA. 95035
Phone: 408-432-1900
LTC Confidential

APPROVALS: DRAWN: MOTHEND / D.PRUITT
CHECKED: R.RANGANATHAN

PIECE PART DRAWING SIP 15MMX9MM BLACK TRAY			
DRAWING NO. 50-8028 REVA			
TOLERANCES UNLESS OTHERWISE SPECIFIED:		DECIMALS XXX ± 0.05	ANGLES ± 1
SCALE N/A	SIZE N/A	SHEET 1 OF 4	

REV	DESCRIPTION	DATE	APPROVED
A	COMPOSITE DRAWING	10/03/07	MD

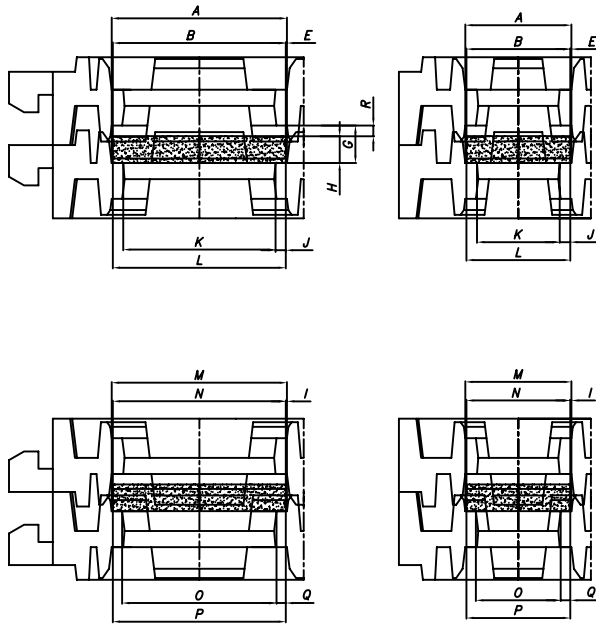

SIMULATION CRITERIA						
1.	A > B	PACKAGE NESTING				
2.	E > D	PACKAGE LATERAL PLAY				
3.	G > H	PACKAGE VERTICAL PLAY				
4.	I > D	PACKAGE LATERAL PLAY AT FLIPPED				
5.	K < L	PACKAGE SEATING				
6.	J > O	PACKAGE SEATING PLAY				
7.	M > N	PACKAGE NESTING AT FLIPPED				
8.	O > P	PACKAGE SEATING AT FLIPPED				
9.	Q > O	PACKAGE SEATING PLAY AT FLIPPED				

No.	Section "A" Condition	Nominal	Max. TRAY Min. PKG		Results
			Wc 1	Wc 2	
1	Tray A	15.200	15.280	15.120	Pass
	Plg. B	15.000	14.900	15.100	Pass
2	Gap. E(A-B/2)	0.100	0.190	0.010	Pass
	Tray G	3.250	3.380	3.120	Pass
3	Plg. H	2.320	2.220	2.420	Pass
	Gap. R(B-I)	0.930	1.160	0.700	Pass
5	Gap. I (M-N/2)	0.100	0.190	0.010	Pass
	Tray K	13.210	13.340	13.080	Pass
6	Plg. L	15.000	14.900	15.100	Pass
	Gap. J (E-H/2)	0.895	0.780	1.010	Pass
7	Tray M	15.200	15.280	15.120	Pass
	Plg. N	15.000	14.900	15.100	Pass
9	Tray O	13.480	13.610	13.350	Pass
	Plg. P	15.000	14.900	15.100	Pass
10	Gap. Q (P-O/2)	0.760	0.645	0.875	Pass

No.	Section "B" Condition	Nominal	Max. TRAY Min. PKG		Results
			Wc 1	Wc 2	
1	Tray A	9.200	9.280	9.120	Pass
	Plg. B	9.000	8.900	9.100	Pass
2	Gap. E(A-B/2)	0.100	0.190	0.010	Pass
	Tray G	3.250	3.380	3.120	Pass
3	Plg. H	2.320	2.220	2.420	Pass
	Gap. R(B-I)	0.930	1.160	0.700	Pass
5	Gap. I (M-N/2)	0.100	0.190	0.010	Pass
	Tray K	7.180	7.310	7.050	Pass
6	Plg. L	9.000	8.900	9.100	Pass
	Gap. J (E-H/2)	0.910	0.795	1.025	Pass
8	Tray M	9.200	9.280	9.120	Pass
	Plg. N	9.000	8.900	9.100	Pass
9	Tray O	7.350	7.480	7.220	Pass
	Plg. P	9.000	8.900	9.100	Pass
10	Gap. Q (P-O/2)	0.825	0.710	0.940	Pass

LINEAR
TECHNOLOGY
1630 McCarthy Blvd.
Milpitas, CA. 95035
Phone: 408-432-1900
LTC Confidential

PIECE PART DRAWING
SIP 15MMX9MM
BLACK TRAY

DRAWING NO.

50-8028 REVA

APPROVALS

DATE:

DRAWN:
MOTHIENO / D.PRUITT

CHECKED:
R.RANGANATHAN

TOLERANCES UNLESS OTHERWISE SPECIFIED:

FRACTIONS

N/A

DECIMALS
0.001 = ± 0.001
0.005 = ± 0.005

ANGLES
± 1

SCALE
N/A

SIZE
N/A

SHEET
2 OF 4

REV	DESCRIPTION	DATE	APPROVED
A	COMPOSITE DRAWING	10/03/07	MO

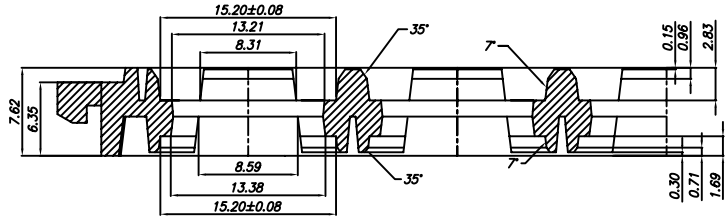

SECTION "A-A"
(SCALE:4/1)

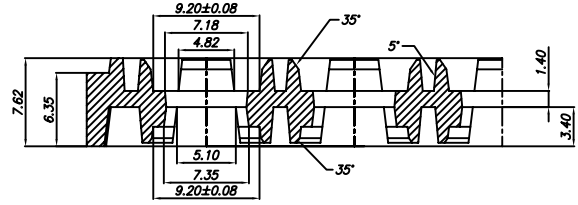

SECTION "B-B"
(SCALE:4/1)

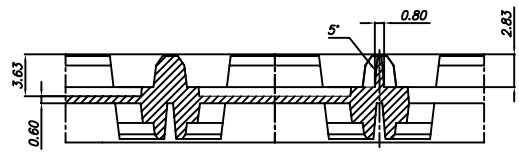

VACUUM CELL
(SCALE:4/1)

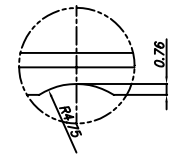

DETAIL "K"
(SCALE:4/1)

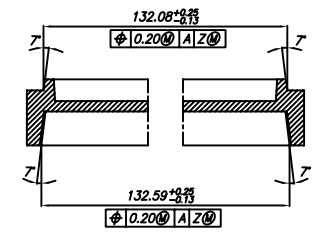
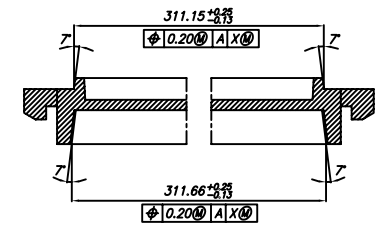

TRAY STACKING DETAIL
(SCALE:4/1)

LINEAR TECHNOLOGY
 1630 McCarthy Blvd.
 Milpitas, CA. 95035
 Phone: 408-432-1900
 LTC Confidential

PIECE PART DRAWING
 SIP 15MMX9MM
 BLACK TRAY

DRAWING NO. 50-8028 REVA

APPROVALS: DRAWN: MOTHEND / D.PRUITT
 CHECKED: R.RANGANATHAN

TOLERANCES UNLESS OTHERWISE SPECIFIED:
 FRACTIONS N/A DECIMALS ±0.005 ±0.013 ANGLES ±1
 SCALE N/A SIZE N/A SHEET 3 OF 4

REV	DESCRIPTION	DATE	APPROVED
A	COMPOSITE DRAWING	10/03/07	MO

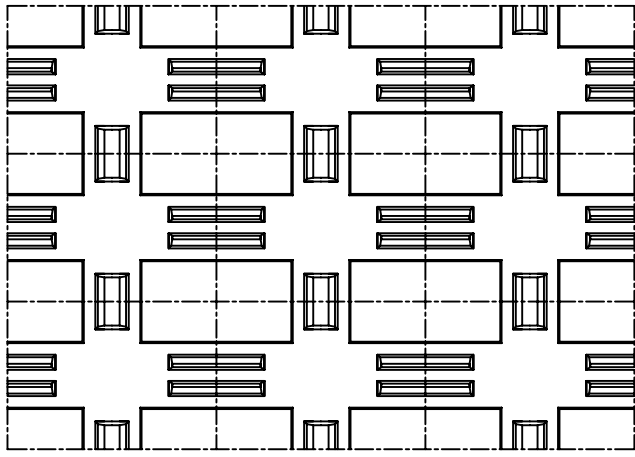

TOP VIEW
(SCALE:4/1)

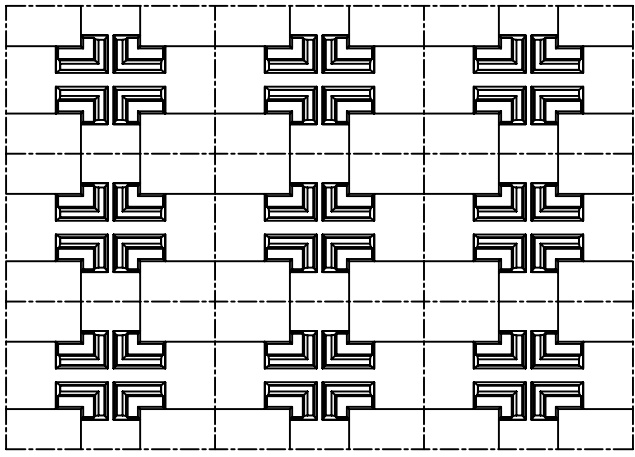

BOTTOM VIEW
(SCALE:4/1)

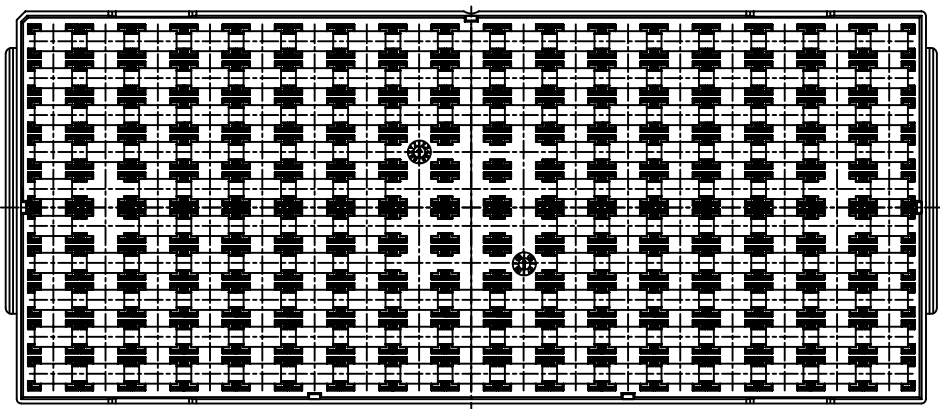

BOTTOM VIEW
(SCALE:1/1)

LINEAR
TECHNOLOGY
1630 McCarthy Blvd.
Milpitas, CA. 95035
Phone: 408-432-1900
LTC Confidential

PIECE PART DRAWING
SIP 15MMX9MM
BLACK TRAY

DRAWING NO.
50-8028 REVA

APPROVALS
DRAWN:
M.DHIEND / D.PRUITT

DATE:

TOLERANCES UNLESS OTHERWISE SPECIFIED:

FRACTIONS
N/A

DECIMALS
0.0005 = ± 0.0005

ANGLES
± 1

CHECKED:
R.RANGANATHAN

SCALE
N/A

SIZE
N/A

SHEET
4 OF 4