

REV	DESCRIPTION	DATE	APPROVED
00	INITIAL COMPOSITE DRAWING		

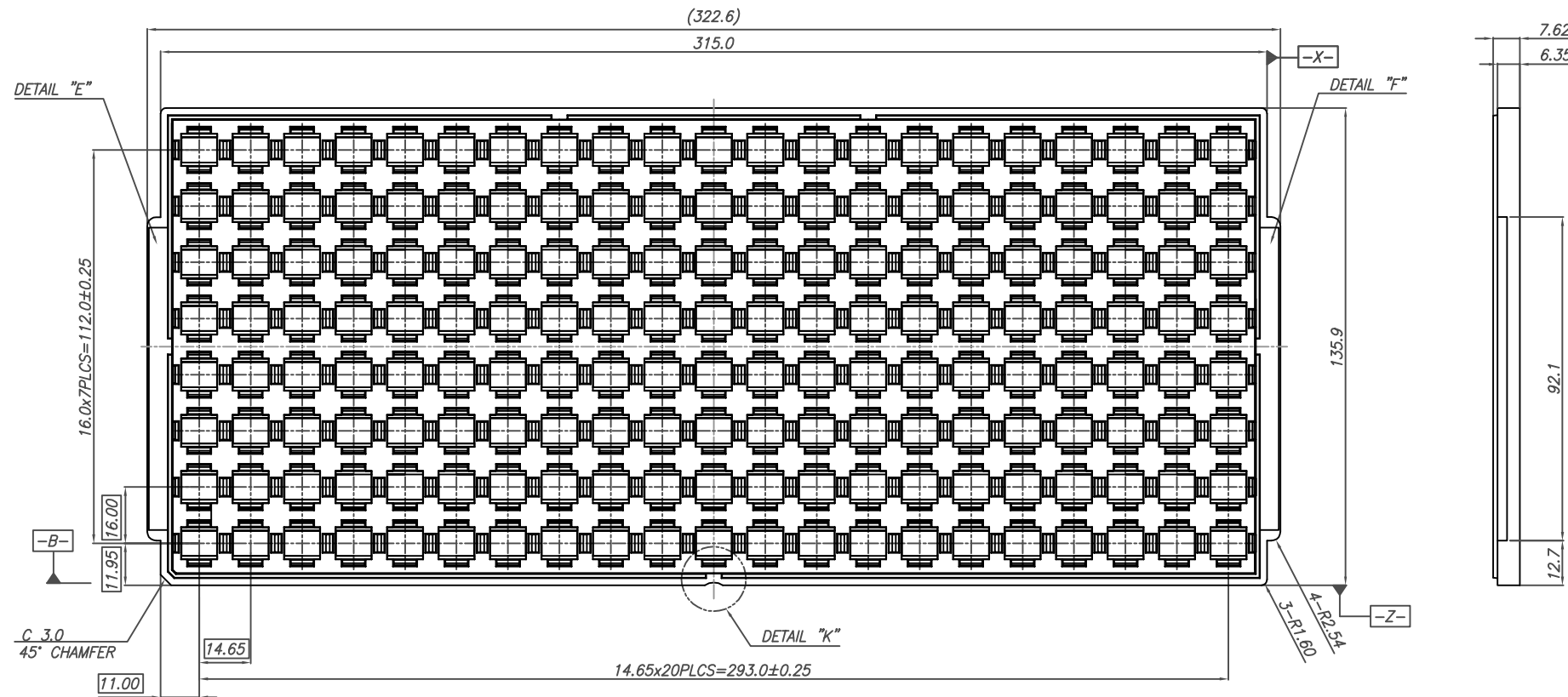

C 3.0
45° CHAMFER

16.0x7 PLCS=112.0±0.25

14.65x20 PLCS=293.0±0.25

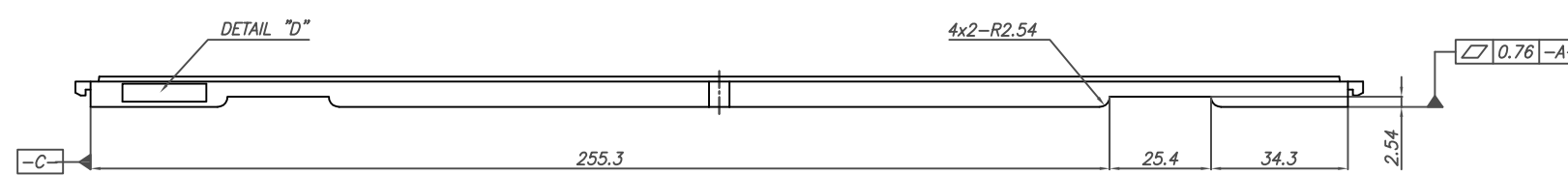

BGA 9.00mm x 11.25mm
KS - 880442 REV.00

KOSTAT BGA 9.00mmx11.25mm 8X21=168

DETAIL "D"
(SCALE:2/1)

DETAIL "E"
(SCALE:2/1)



DATE DETAIL
(SCALE:2/1)

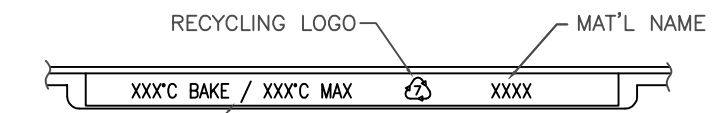

DETAIL "F"
(SCALE:2/1)

LINEAR
TECHNOLOGY
1630 McCarthy Blvd.
Milpitas, CA. 95035
Phone: 408-432-1900
LTC Confidential

PIECE PART DRAWING
BGA 9.00mm x 11.25mm
BLACK TRAY

DRAWING NO.
50-8066 REV0

APPROVALS: DRAWN: M.OTHEND / D.PRUITT
CHECKED: R.RANGANATHAN

TOLERANCES UNLESS OTHERWISE SPECIFIED:		
FRACTIONS N/A	DECIMALS XXXX = ± 0.25 XX.XXX = ± 0.13	ANGLES ± 1
SCALE N/A	SIZE N/A	SHEET 1 OF 4

REV	DESCRIPTION	DATE	APPROVED
00	INITIAL COMPOSITE DRAWING		

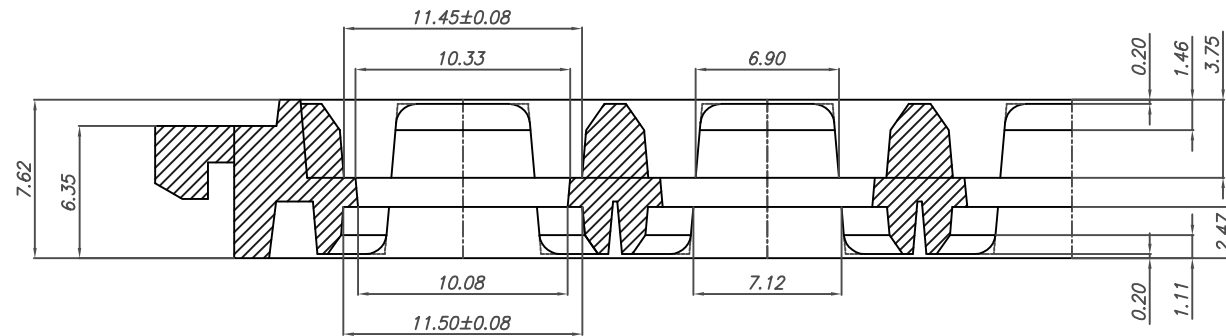

SECTION "A-A"
(SCALE:5/1)

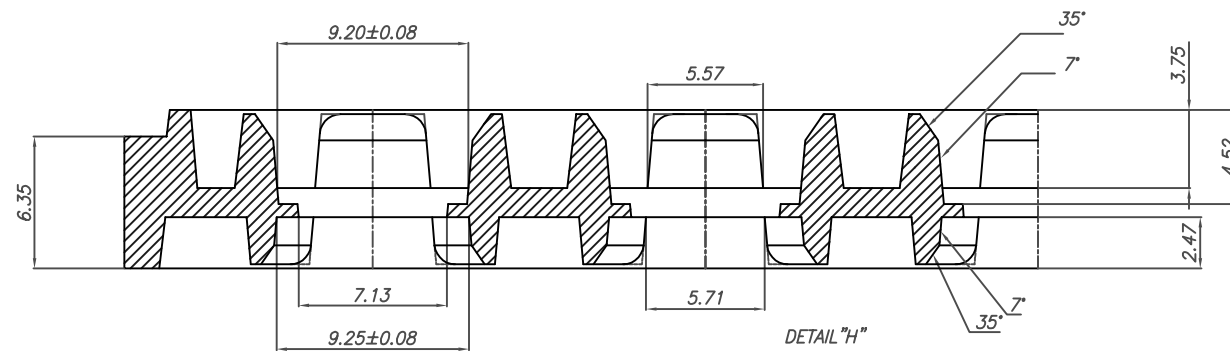

SECTION "B-B"
(SCALE:5/1)

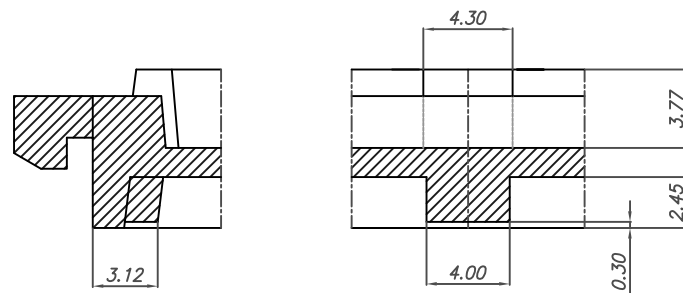

SLIP LOCK
(SCALE:5/1)

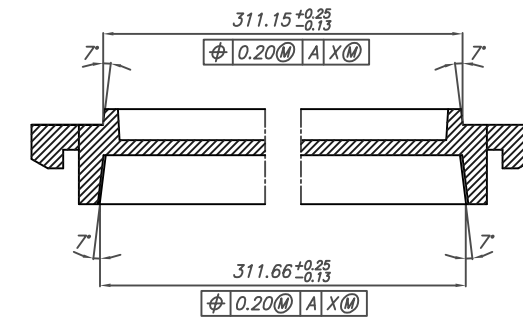

TRAY STACKING DETAIL
(SCALE:4/1)

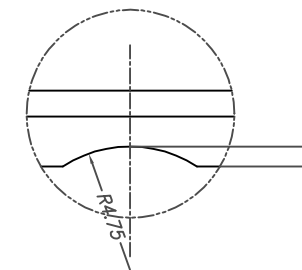

DETAIL "K"
(SCALE:5/1)

 1630 McCarthy Blvd. Milpitas, CA. 95035 Phone: 408-432-1900 LTC Confidential	PIECE PART DRAWING BGA 9.00mm x 11.25mm BLACK TRAY		
	DRAWING NO. 50-8066 REV0		
APPROVALS DRAWN: M.DTHIEND / D.PRUITT CHECKED: R.RANGANATHAN	DATE:	TOLERANCES UNLESS OTHERWISE SPECIFIED: FRACTIONS N/A DECIMALS xx.xx = ± 0.25 xxx.xxx = ± 0.13 ANGLES ± 1	
SCALE N/A	SIZE N/A	SHEET 2 OF 4	

REV	DESCRIPTION	DATE	APPROVED
00	INITIAL COMPOSITE DRAWING		

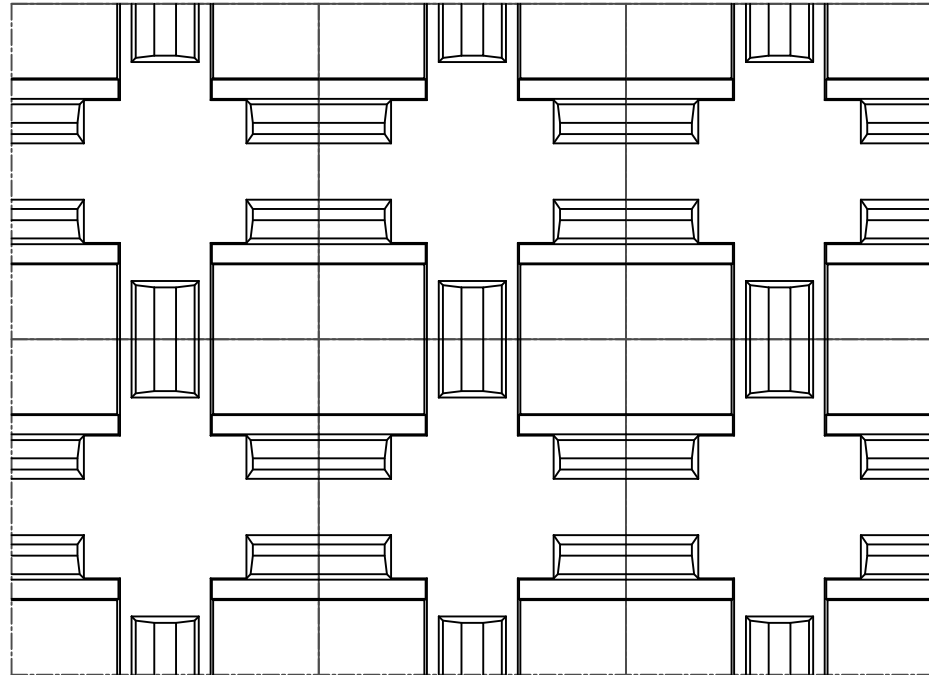

TOP VIEW
(SCALE:5/1)

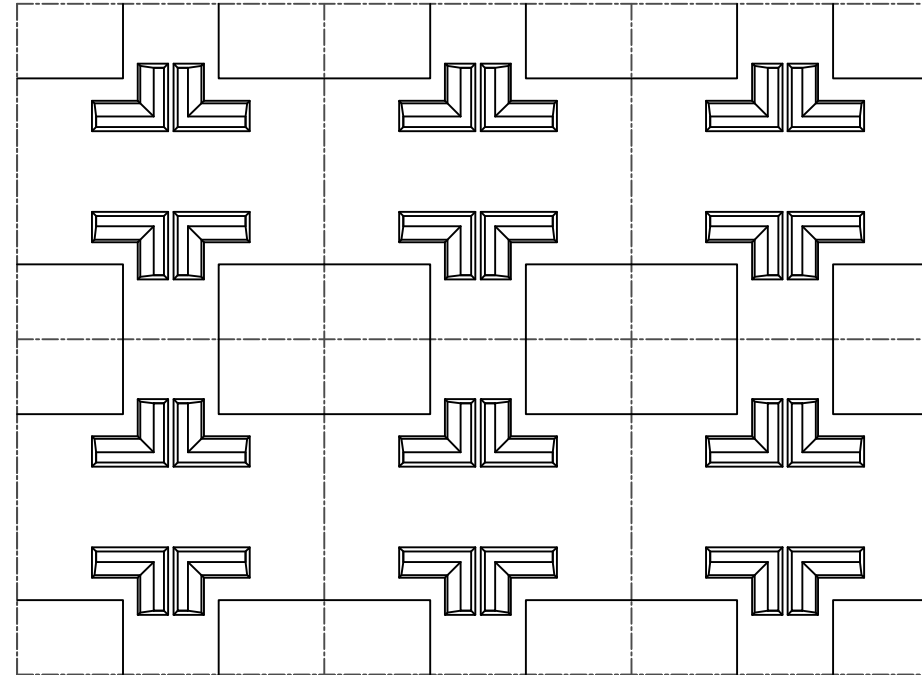

BOTTOM VIEW
(SCALE:5/1)

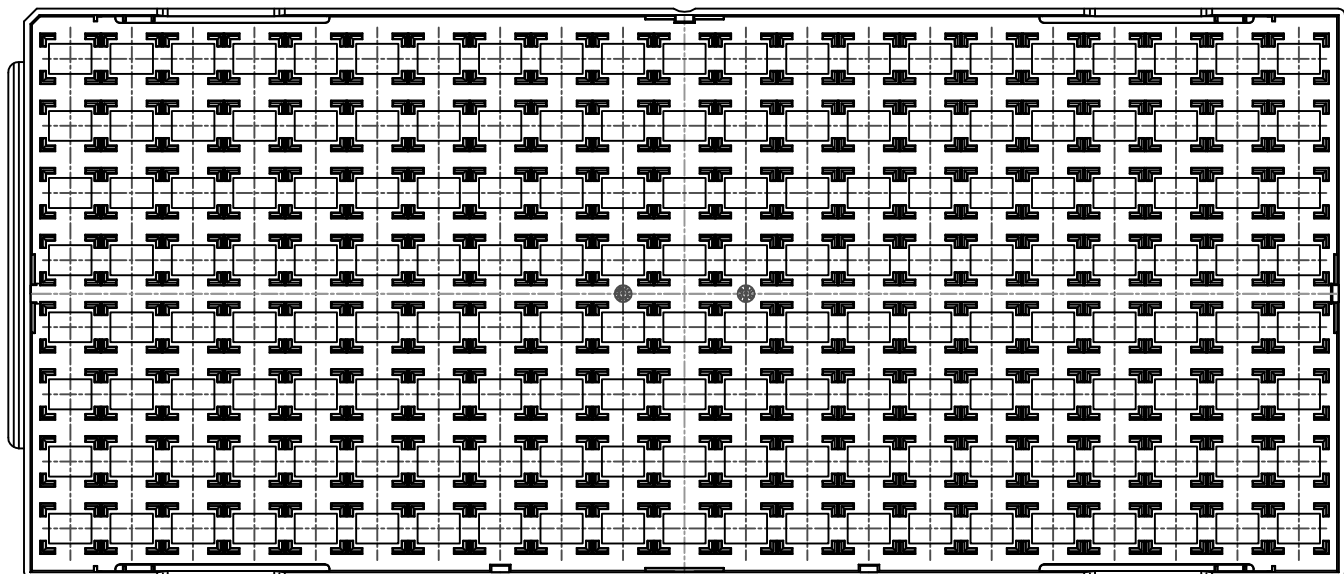

BOTTOM VIEW
(SCALE:1/1)

LINEAR
TECHNOLOGY
1630 McCarthy Blvd.
Milpitas, CA. 95035
Phone: 408-432-1900
LTC Confidential

PIECE PART DRAWING
BGA 9.00mm x 11.25mm
BLACK TRAY

DRAWING NO.
50-8066 REV0

APPROVALS: _____ DATE: _____
DRAWN: M.DTHIEND / D.PRUITT
CHECKED: R.RANGANATHAN

TOLERANCES UNLESS OTHERWISE SPECIFIED:
FRACTIONS N/A DECIMALS .xxx = ± 0.25 .xx.xxx = ± 0.13 ANGLES ± 1
SCALE N/A SIZE N/A SHEET 3 OF 4

REV	DESCRIPTION	DATE	APPROVED
00	INITIAL COMPOSITE DRAWING		

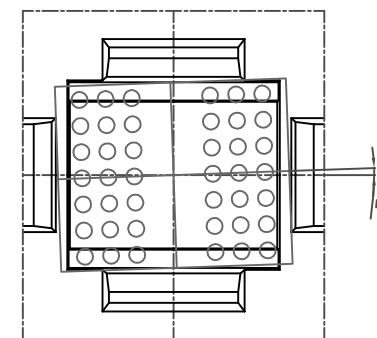
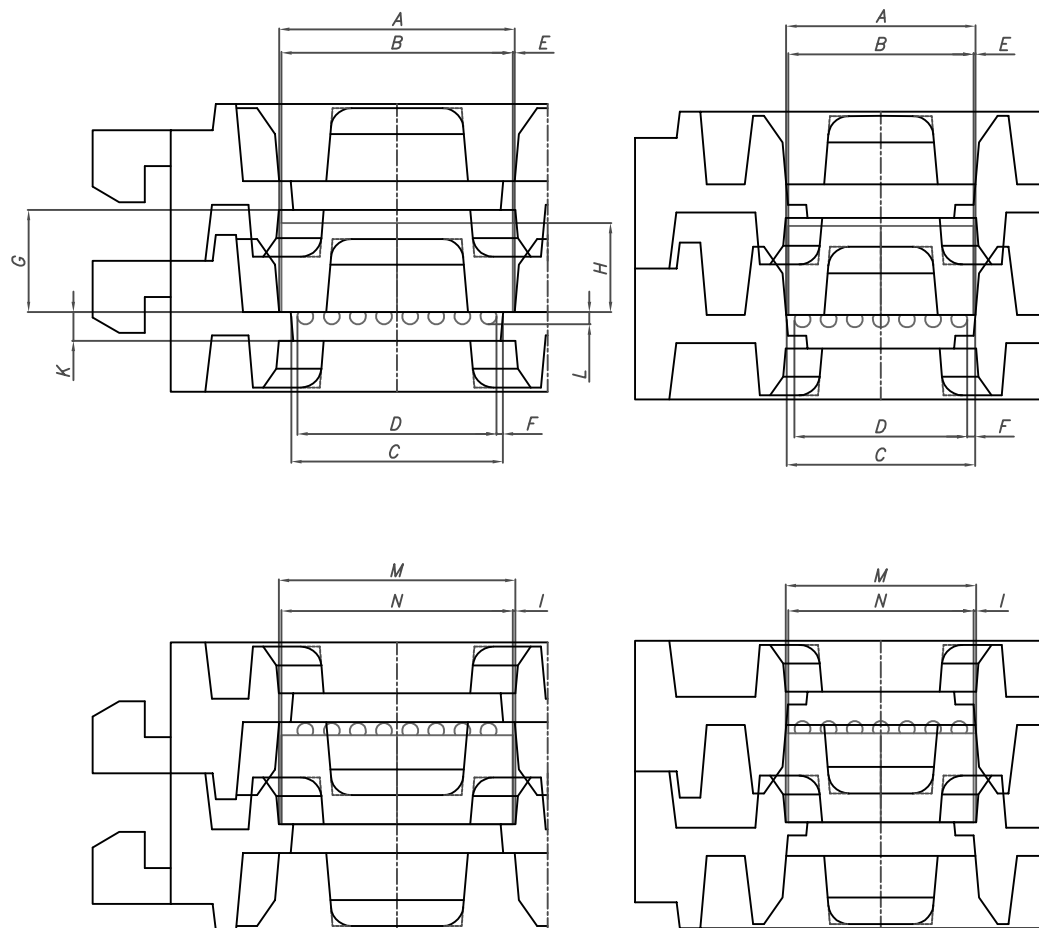

SIMULATION CRITERIA	
1. $A > B$	PACKAGE LATERAL PLAY
2. $C > D$	BALL LATERAL PLAY
3. $E < F$	BALL TOUCH THE SHELVE
4. $G > H$	PACKAGE VERTICAL PLAY
5. $I > \text{Zero}$	PACKAGE LATERAL PLAY (FLIPPED)
6. $K > L$	BALL TOUCH THE FLOOR
7. $M > N$	PACKAGE LATERAL PLAY (FLIPPED)

Section A-A					
No.	Condition	Nominal	Max. TRAY Min. PKG	Min. TRAY Max. PKG	Results
1	Tray A	11.450	11.530	11.370	Pass
	Pkg. B	11.250	11.150	11.350	
2	Tray C	10.290	10.420	10.160	Pass
	Pkg. D	9.680	9.630	9.730	
3	Gap. $E(A-B/2)$	0.100	0.190	0.010	Pass
	Gap. $F(C-D/2)$	0.305	0.395	0.215	
4	Tray G	4.960	5.090	4.830	Pass
	Pkg. H	4.320	4.220	4.420	
5	Gap. $I(M-N/2)$	0.125	0.215	0.035	Pass
	Gap. $J(O-P/2)$	-	-	-	
6	Tray K	1.400	1.530	1.270	Pass
	Pkg. L	0.600	0.500	0.700	
7	Tray M	11.500	11.580	11.420	Pass
	Pkg. N	11.250	11.150	11.350	

Section B-B					
No.	Condition	Nominal	Max. TRAY Min. PKG	Min. TRAY Max. PKG	Results
1	Tray A	9.200	9.280	9.120	Pass
	Pkg. B	9.000	8.900	9.100	
2	Tray C	9.160	9.290	9.030	Pass
	Pkg. D	8.400	8.350	8.450	
3	Gap. $E(A-B/2)$	0.100	0.190	0.010	Pass
	Gap. $F(C-D/2)$	0.380	0.470	0.290	
4	Tray G	4.960	5.090	4.830	Pass
	Pkg. H	4.320	4.220	4.420	
5	Gap. $I(M-N/2)$	0.125	0.215	0.035	Pass
	Gap. $J(O-P/2)$	-	-	-	
6	Tray K	1.400	1.530	1.270	Pass
	Pkg. L	0.600	0.500	0.700	
7	Tray M	9.250	9.330	9.170	Pass
	Pkg. N	9.000	8.900	9.100	



1630 McCarthy Blvd.
Milpitas, CA 95035
Phone: 408-432-1900
LTC Confidential

PIECE PART DRAWING
BGA 9.00mm x 11.25mm
BLACK TRAY

DRAWING NO.
50-8066 REV0

APPROVALS: DRAWN: M.OTHEND / D.PRUITT
CHECKED: R.RANGANATHAN

TOLERANCES UNLESS OTHERWISE SPECIFIED:
FRACTIONS N/A DECIMALS .XXXX = ± 0.25 .XX.XXX = ± 0.13
SCALE N/A SIZE N/A SHEET 4 OF 4