

REV	DESCRIPTION	DATE	APPROVED
0	initial composite drawing		

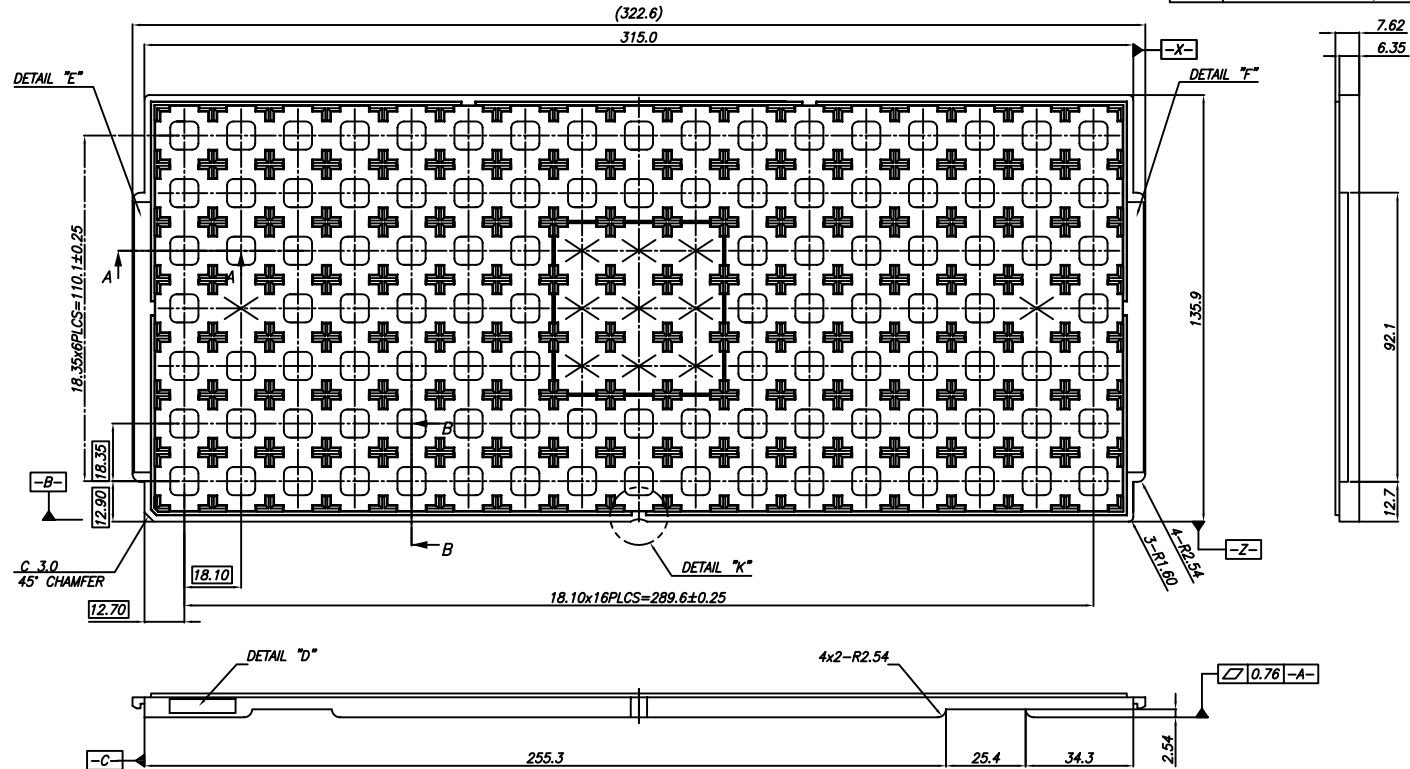

BGA 15.00x15.00x4.92mm
KS-880440 REV.00

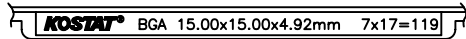

DETAIL "D"
(SCALE:2/1)

DETAIL "E"
(SCALE:2/1)



DATE DETAIL
(SCALE:2/1)

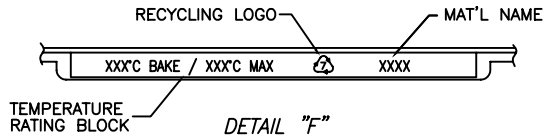

DETAIL "F"
(SCALE:2/1)

LINEAR
TECHNOLOGY
1630 McCarthy Blvd.
Milpitas, CA, 95035
Phone: 408-432-1900
LTC Confidential

PIECE PART DRAWING
BGA 15.00x15.00x4.92mm
BLACK TRAY

DRAWING NO.
50-8072 REV0

APPROVALS	DATE:	TOLERANCES UNLESS OTHERWISE SPECIFIED:		
DRAWN: M.OTHIEHD / D.PRUITT		FRACTIONS N/A	DECIMALS XXX ± 0.25 XXXX ± 0.13	ANGLES ± 1
CHECKED: R.RANGANATHAN		SCALE N/A	SIZE N/A	SHEET 1 OF 6

REV	DESCRIPTION	DATE	APPROVED
0	initial composite drawing		

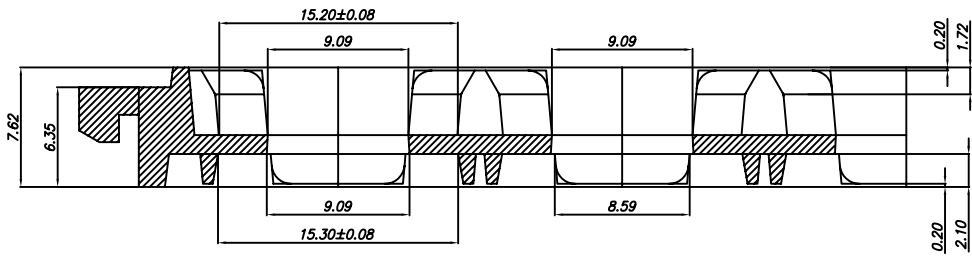

SECTION "A-A"
(SCALE:5/1)

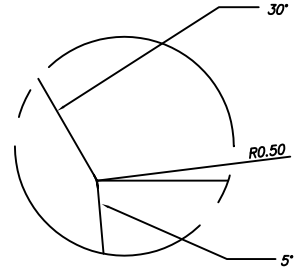

DETAIL "G"
(SCALE:20/1)

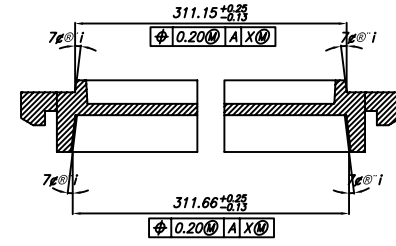

TRAY STACKING DETAIL
(SCALE:3/1)

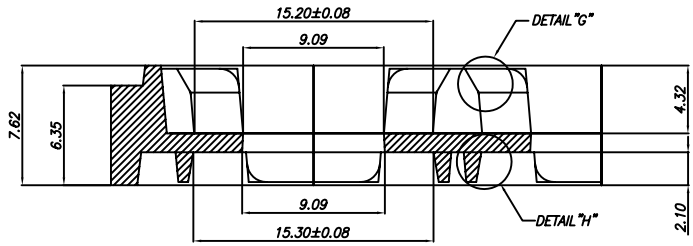

SECTION "B-B"
(SCALE:5/1)

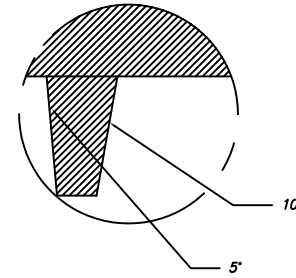

DETAIL "H"
(SCALE:20/1)

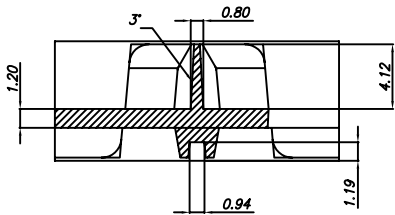

VACUUM CELL
(SCALE:5/1)

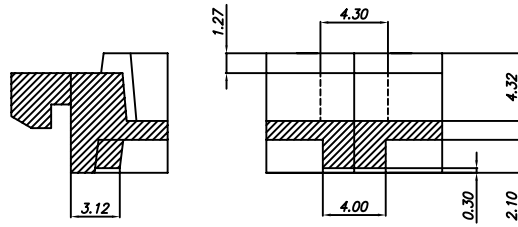

SLIP LOCK DETAIL
(SCALE:5/1)

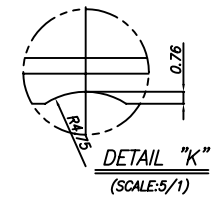

DETAIL "K"
(SCALE:5/1)

 1630 McCarthy Blvd. Milpitas, CA. 95035 Phone: 408-432-1900 LTC Confidential		PIECE PART DRAWING BGA 15.00x15.00x4.92mm BLACK TRAY	
		DRAWING NO. 50-8072 REV0	
APPROVALS: _____ DATE: _____		TOLERANCES UNLESS OTHERWISE SPECIFIED:	
DRAWN: M.OTHIEIND / D.PRUITT	CHECKED: R.RANGANATHAN	FRACTIONS N/A	DECIMALS XXXX ± 0.005 XXXX ± 0.013
		SCALE N/A	ANGLES ± 1
		SIZE N/A	SHEET 2 OF 6

REV	DESCRIPTION	DATE	APPROVED
0	initial composite drawing		

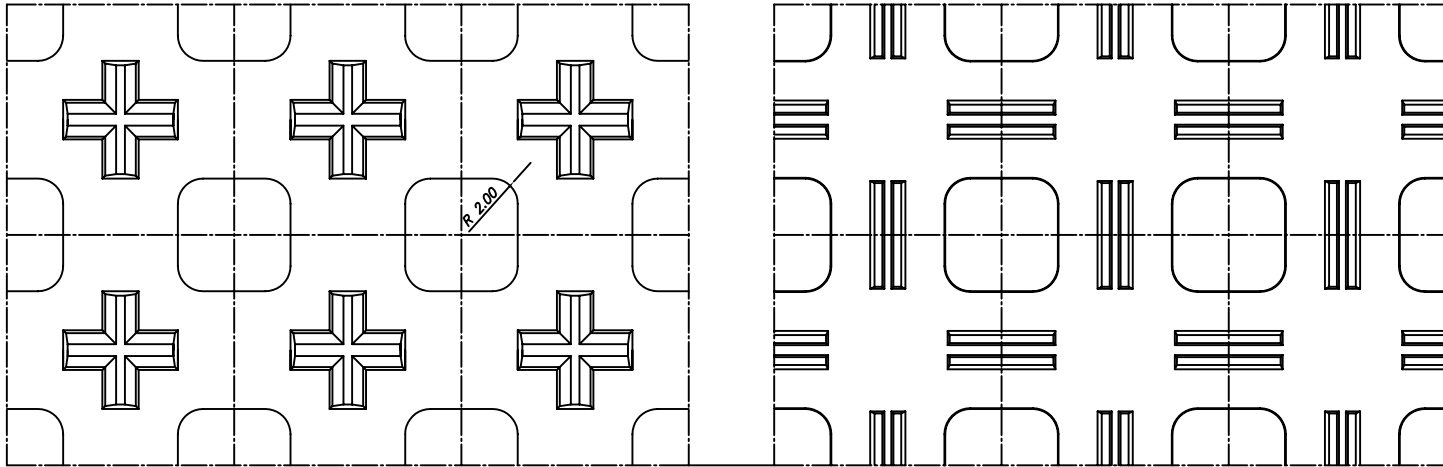

TOP VIEW
(SCALE:4/1)

BOTTOM VIEW
(SCALE:4/1)

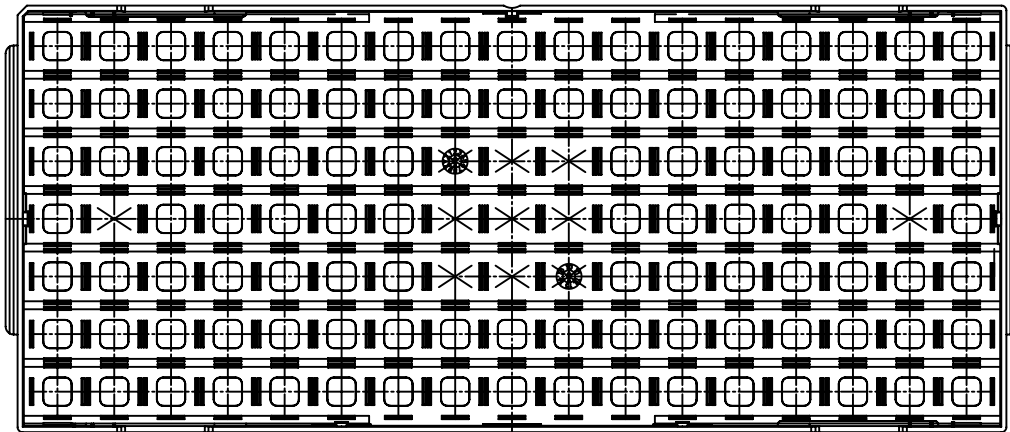

BOTTOM VIEW
(SCALE:1/1)

LINEAR
TECHNOLOGY
1630 McCarthy Blvd.
Milpitas, CA. 95035
Phone: 408-432-1900
LTC Confidential

PIECE PART DRAWING
BGA 15.00x15.00x4.92mm
BLACK TRAY

DRAWING NO.

50-8072 REV0

APPROVALS DATE:

DRAWN:
M.OTHIEHD / D.PRUITT

CHECKED:
R.RANGANATHAN

TOLERANCES UNLESS OTHERWISE SPECIFIED:

FRACTIONS
N/A

DECIMALS
XXXX = ± 0.25
XXXXX = ± 0.13

ANGLES
± 1

SCALE
N/A

SIZE
N/A

SHEET
3 OF 6

Package Body Size	BGA 15.00mm x15.00 mm
LTC Package Dwg. no.	LTC- 05-08-1880 REV.00
Kostat Tray Dwg. no.	KS-880440

REV	DESCRIPTION	DATE	APPROVED
0	initial composite drawing		

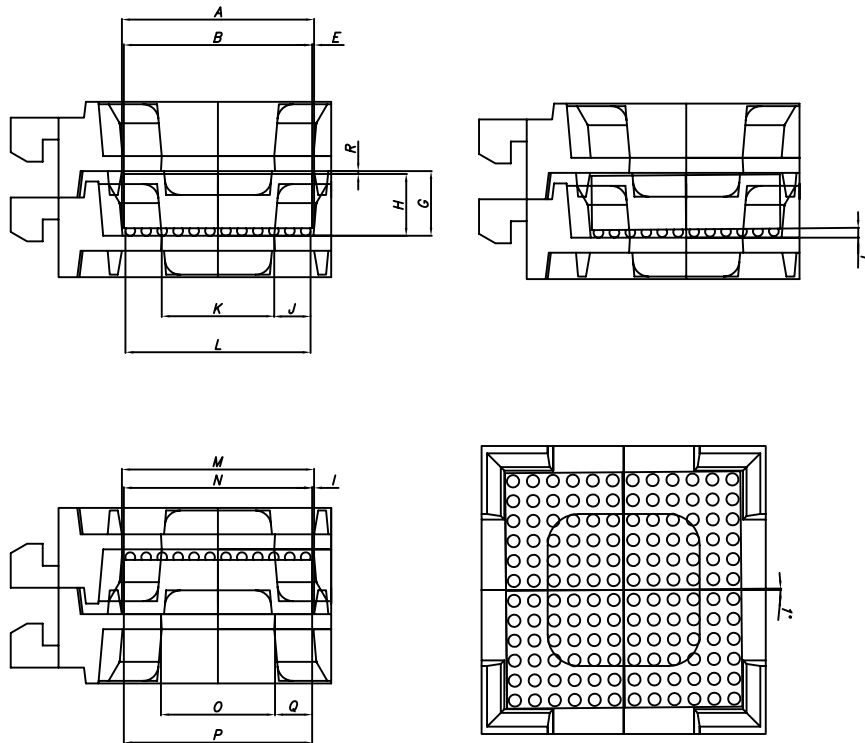

SIMULATION CRITERIA					
1.	$A > B$	PACKAGE NESTING			
2.	$E > 0$	PACKAGE LATERAL PLAY			
3.	$G > H$	PACKAGE VERTICAL PLAY			
4.	$I > 0$	PACKAGE LATERAL PLAY AT FLIPPED			
5.	$K < L$	PACKAGE SEATING			
6.	$J > 0$	PACKAGE SEATING PLAY			
7.	$M > N$	PACKAGE NESTING AT FLIPPED			
8.	$O < P$	PACKAGE SEATING AT FLIPPED			
9.	$Q > 0$	PACKAGE SEATING PLAY AT FLIPPED			
No.	Section "AA" Condition	Nominal	Max. TRAY Min. PKG Wc 1	Min. TRAY Max. PKG Wc 2	Results
1	Tray A	15.300	15.380	15.220	Pass
	Pkg. B	15.000	14.900	15.100	
2	Gap. $E(A-B/2)$	0.150	0.240	0.060	Pass
3	Tray G	5.150	5.280	5.020	Pass
	Pkg. H	4.920	4.720	5.120	
4	Gap. $R(G-H)$	0.230	0.560	-0.100	Pass
5	Gap. $I(M-N)/2$	0.150	0.240	0.060	Fail
6	Tray K	8.970	9.100	8.840	Pass
	Pkg. L	14.750	14.680	14.820	
7	Gap. $J(L-K/2)$	2.890	2.790	2.990	Pass
8	Tray M	15.300	15.380	15.220	Pass
	Pkg. N	15.000	14.900	15.100	
9	Tray O	9.090	9.220	8.960	Pass
	Pkg. P	15.000	14.900	15.100	
10	Gap. $Q(P-O/2)$	2.955	2.840	3.070	Pass

LINEAR
TECHNOLOGY
1630 McCarthy Blvd.
Milpitas, CA. 95035
Phone: 408-432-1900
LTC Confidential

PIECE PART DRAWING
BGA 15.00x15.00x4.92mm
BLACK TRAY

DRAWING NO.

50-8072 REV0

APPROVALS DATE:

DRAWN:
M.OTHIEIND / D.PRUITT

CHECKED:
R.RANGANATHAN

TOLERANCES UNLESS OTHERWISE SPECIFIED:

FRACTIONS
N/A

DECIMALS
 $\frac{XXX}{1000} = \pm 0.003$

ANGLES
 ± 1

SCALE
N/A

SIZE
N/A

SHEET
4 OF 6

Package Body Size	BGA 15.00mm x15.00 mm
LTC Package Dwg. no.	LTC- 05-08-1877 REV.00
Kostat Tray Dwg. no.	KS-880440

REV	DESCRIPTION	DATE	APPROVED
0	initial composite drawing		

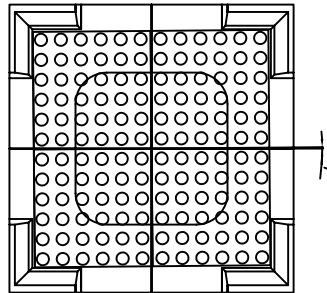
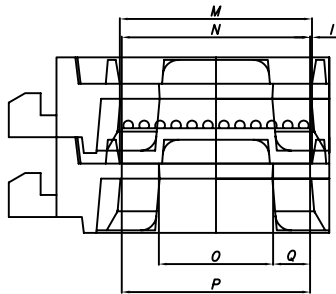
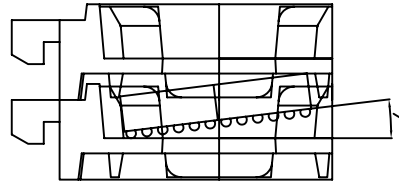
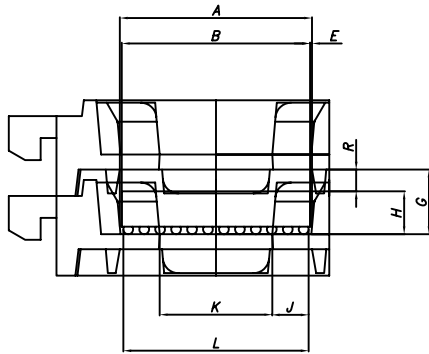

SIMULATION CRITERIA						
1. $A > B$		PACKAGE NESTING				
2. $E > 0$		PACKAGE LATERAL PLAY				
3. $G > H$		PACKAGE VERTICAL PLAY				
4. $I > 0$		PACKAGE LATERAL PLAY AT FLIPPED				
5. $K < L$		PACKAGE SEATING				
6. $J > 0$		PACKAGE SEATING PLAY				
7. $M > N$		PACKAGE NESTING AT FLIPPED				
8. $O < P$		PACKAGE SEATING AT FLIPPED				
9. $Q > 0$		PACKAGE SEATING PLAY AT FLIPPED				
No.	Section "AA" Condition	Nominal	Max. TRAY Min. PKG Wc 1	Min. TRAY Max. PKG Wc 2	Results	
1	Tray A	15.300	15.380	15.220	Pass	
	Pkg. B	15.000	14.900	15.100		
2	Gap. $E(A-B/2)$	0.150	0.240	0.060	Pass	
3	Tray G	5.150	5.280	5.020	Pass	
	Pkg. H	3.420	3.220	3.620		
4	Gap. $R(G-H)$	1.730	2.060	1.400	Pass	
5	Gap. $I(M-N)/2$	0.150	0.240	0.060	Pass	
6	Tray K	8.970	9.100	8.840	Pass	
	Pkg. L	14.750	14.680	14.820		
7	Gap. $J(L-K/2)$	2.890	2.790	2.990	Pass	
8	Tray M	15.300	15.380	15.220	Pass	
	Pkg. N	15.000	14.900	15.100		
9	Tray O	9.090	9.220	8.960	Pass	
	Pkg. P	15.000	14.900	15.100		
10	Gap. $Q(P-O/2)$	2.955	2.840	3.070	Pass	

LINEAR
TECHNOLOGY
1630 McCarthy Blvd.
Milpitas, CA. 95035
Phone: 408-432-1900
LTC Confidential

PIECE PART DRAWING
BGA 15.00x15.00x4.92mm
BLACK TRAY

DRAWING NO.

50-8072 REV0

APPROVALS DATE:

DRAWN:
M.OTHIEIND / D.PRUITT

CHECKED:
R.RANGANATHAN

TOLERANCES UNLESS OTHERWISE SPECIFIED:

FRACTIONS
N/A

DECIMALS
XXXX ± 0.003
XXXX ± 0.003

ANGLES
± 1

SCALE
N/A

SIZE
N/A

SHEET
5 OF 6

Package Body Size	LGA 15.00mm x15.00 mm
LTC Package Dwg. no.	LTC- 05-08-1861 REV.00
Kostat Tray Dwg. no.	KS-880440

REV	DESCRIPTION	DATE	APPROVED
0	initial composite drawing		

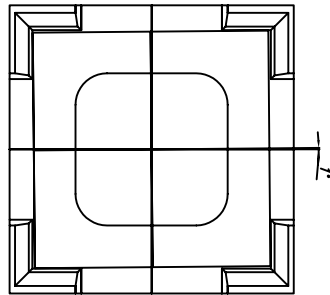
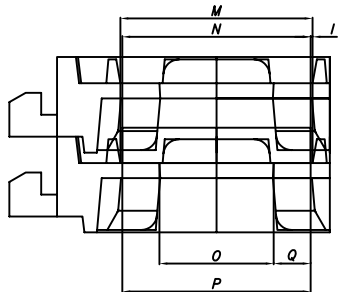
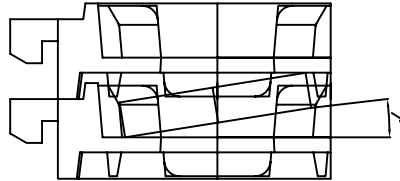
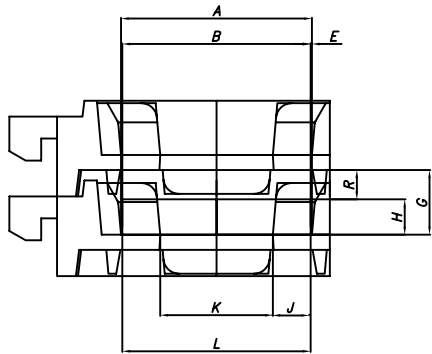

SIMULATION CRITERIA					
1. $A > B$		PACKAGE NESTING			
2. $E > 0$		PACKAGE LATERAL PLAY			
3. $G > H$		PACKAGE VERTICAL PLAY			
4. $I > 0$		PACKAGE LATERAL PLAY AT FLIPPED			
5. $K < L$		PACKAGE SEATING			
6. $J > 0$		PACKAGE SEATING PLAY			
7. $M > N$		PACKAGE NESTING AT FLIPPED			
8. $O < P$		PACKAGE SEATING AT FLIPPED			
9. $Q > 0$		PACKAGE SEATING PLAY AT FLIPPED			
No.	Section "AA" Condition	Nominal	Max. TRAY Min. PKG Wc 1	Min. TRAY Max. PKG Wc 2	Results
1	Tray A	15.200	15.280	15.120	Pass
	Pkg. B	15.000	14.900	15.100	
2	Gap. $E(A-B/2)$	0.100	0.190	0.010	Pass
3	Tray G	5.150	5.280	5.020	Pass
	Pkg. H	2.820	2.620	3.020	
4	Gap. $R(G-H)$	2.330	2.660	2.000	Pass
5	Gap. $I(M-N)/2$	0.150	0.240	0.060	Pass
6	Tray K	8.970	9.100	8.840	Pass
	Pkg. L	15.000	14.900	15.100	
7	Gap. $J(L-K/2)$	3.015	2.900	3.130	Pass
8	Tray M	15.300	15.380	15.220	Pass
	Pkg. N	15.000	14.900	15.100	
9	Tray O	9.090	9.220	8.960	Pass
	Pkg. P	15.000	14.900	15.100	
10	Gap. $Q(P-O/2)$	2.955	2.840	3.070	Pass

LINEAR
TECHNOLOGY
1630 McCarthy Blvd.
Milpitas, CA 95035
Phone: 408-432-1900
LTC Confidential

PIECE PART DRAWING
BGA 15.00x15.00x4.92mm
BLACK TRAY

DRAWING NO.
50-8072 REV0

APPROVALS	DATE:	TOLERANCES UNLESS OTHERWISE SPECIFIED:
DRAWN: M.OTHIEHD / D.PRUITT		FRACTIONS N/A
CHECKED: R.RANGANATHAN		DECIMALS $\frac{XXXX}{1000} = \pm 0.003$ ANGLES ± 1
		SCALE N/A
		SIZE N/A
		SHEET 6 OF 6