

DESIGN NOTES

Versatile High Power LED Driver Controller Simplifies Design

Design Note 406

Ryan Huff

Introduction

The increased popularity of high power LEDs over the last several years has challenged electronic engineers to come up with accurate and efficient, yet simple drive solutions. The task is more difficult as the market for LEDs enters the realm of high-powered lights, such as those for automobile headlights or large LCD backlights. High light-output solutions usually involve large arrays of individual LEDs stacked in series. Conventionally, driving high power strings with accurate current is at odds with simplicity and efficiency—typically involving an inefficient linear regulator scheme or a more complicated, multiple IC switching regulator configuration. There is a simpler and better way via a low parts count, single IC solution for driving high power LED strings. At the heart of this highly efficient, simple and accurate solution is the LTC3783 controller IC.

Fully Integrated, High Power LED Driver Controller

The LTC3783 has all of the functions that are normally required to run an LED string: an accurate current regulation error amplifier, a switch mode power supply (SMPS) controller with FET drivers, and two different ways to control the brightness of the LED string.

The current regulating error amplifier uses the voltage drop across a sense resistor in series with the LED string

to precisely regulate the LED current. The SMPS control portion of the LTC3783 takes advantage of current mode operation to easily compensate the loop response of the many possible topologies such as boost, buck, buck-boost, flyback and SEPIC. The integrated FET drivers allow fast switching of the power MOSFETs that are needed to efficiently convert input power to LED power without having to add external gate drive ICs.

LED Dimming

Two different ways of controlling LED brightness are included. Analog dimming varies the LED current from a maximum value down to about 10% of this maximum (a 10:1 dimming range). Since an LED color spectrum is related to current, this approach is not appropriate for some applications. However, PWM or digital dimming, switches between zero current and the maximum LED current at a rate fast enough that visual flicker is not apparent, typically greater than 100Hz. The duty cycle changes the effective average current. This method allows up to a 3000:1 dimming range, limited only by the minimum duty cycle. Because the LED current is either maximum or off, this method also has the advantage of avoiding LED color shifts that come with the current changes associated with analog dimming.

LT, LTC and LTM are registered trademarks of Linear Technology Corporation. All other trademarks are the property of their respective owners.

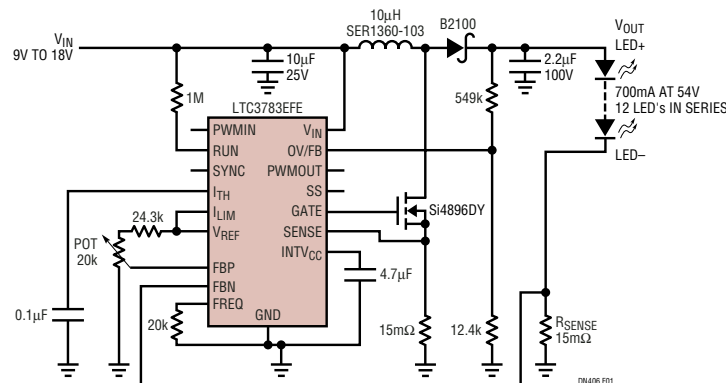

Figure 1. LTC3783 in a Boost Configuration to Drive 12 LEDs in Series

Boost Circuit

Figure 1 shows a boost configuration using all off-the-shelf components. The input voltage, which ranges from 9V to 18V, is boosted to an LED string voltage of 30V to 54V. The LED string can consist of twelve, 700mA LEDs of any color in series for a total of up to 38W of LED power. At an input voltage of 18V and an LED string voltage of 54V, this circuit achieves an astounding power efficiency of over 95%! This high efficiency results in no greater than a 25°C temperature rise for any circuit component.

Buck-Boost Circuit

Figure 2 shows a buck-boost solution that can be used when the input voltage range overlaps the LED string voltage. Here the input voltage ranges from 9V to 36V and the LED string ranges from 18V to 37V. This 8-LED series string runs up to 1.5A. At the nominal input voltage of 14.4V and an LED string voltage of 36V at 1.5A (54W output power), the efficiency is almost 93%. Again, this was achieved using exclusively off-the-shelf components.

LED Protection and Other Features

The LTC3783 can operate from a wide 3V to 36V (or higher) input voltage supply range. A programmable undervoltage lockout ensures that too low of an input voltage is ignored by the chip. If an LED string is inadvertently left open, an overvoltage protection feature ensures that the output voltage does not exceed a programmable level. A soft-start function is included in order to limit the in-rush of current from the input supply during start-up. The switching frequency can be set by a single resistor to any value between 20kHz and 1MHz, or it can be synchronized to an external clock.

Conclusion

Driving high power LED strings with the LTC3783 yields a highly efficient, low parts count and flexible solution. Furthermore, being able to use standard off-the-shelf components helps to simplify the design without sacrificing performance.

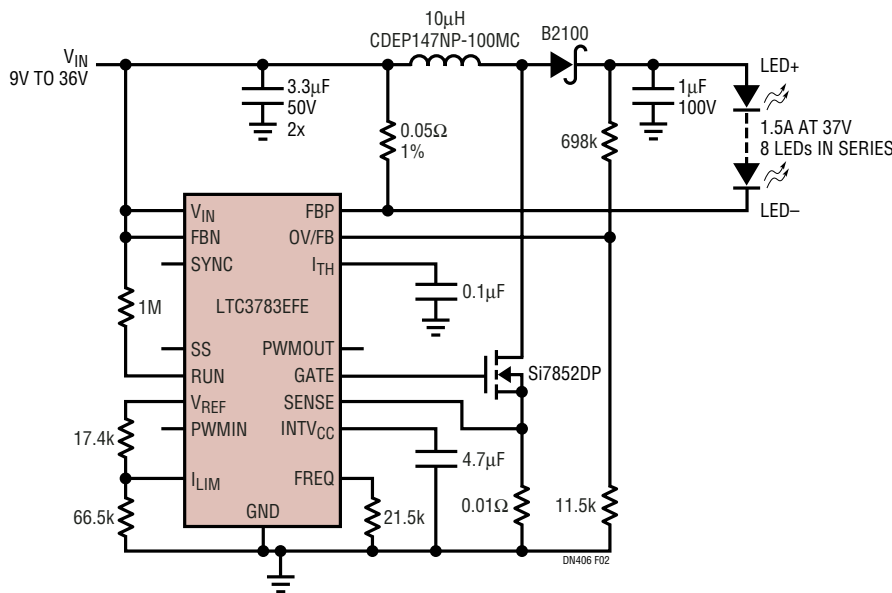

Figure 2. LTC3783 in a Buck-Boost Configuration to Drive 8 LEDs in Series

Data Sheet Download

www.linear.com

For applications help,
call (408) 432-1900, Ext. 3209

Linear Technology Corporation
1630 McCarthy Blvd., Milpitas, CA 95035-7417
(408) 432-1900 • FAX: (408) 434-0507 • www.linear.com

dn406f LT/TP 0107 305K • PRINTED IN THE USA

© LINEAR TECHNOLOGY CORPORATION 2006