

# Low $I_Q$ , Triple Output Boost/Buck/Buck Synchronous Controller Keeps Electronics Running Through Battery Transients in Automotive Start-Stop and Always-On Systems

Joe Panganiban and Jason Leonard

Several automotive manufacturers use the concept of a “start-stop” system to improve fuel economy and reduce emissions for vehicles that spend a significant amount of time at traffic lights and in heavy, stop-and-go traffic. This system automatically turns off the internal combustion engine whenever the car is at a complete stop and then restarts it immediately when the driver wants to go. This reduces the amount of time the engine spends idling, thus saving fuel. Start-stop systems have been installed in hybrid-electric vehicles for years, but are now becoming more common in traditional vehicles (with both manual and automatic transmissions) that lack a hybrid-electric powertrain.

Typically, a central control unit coordinates the start-stop system to ensure that driver comfort and safety are not compromised. For example, the system is not activated if the air conditioner has not brought the cabin to the desired temperature or if the driver moves the steering wheel. However, there are many systems, such as navigation, telematics and infotainment systems (CD and DVD players, audio systems, etc.) that remain active when the engine is off. These systems often operate from 5V–10V supplies generated by step-down (buck) converters from the nominally 12V car battery. When the engine starts, the battery voltage can dip to well below 5V, potentially causing these systems to glitch or reset.

In a vehicle with a start-stop system, the engine by definition restarts frequently. While it may not present a safety risk if your DVD or CD player restarts every time you stop at a traffic light, it certainly is annoying, especially for a parent relying on the DVD player to babysit the kids in the back seat.

Fortunately, Linear Technology has the solution. The LTC3859 combines a synchronous boost controller with two

synchronous buck controllers in a single package. To achieve the wide input voltage range required in the automotive applications described above, the part can be configured with the vehicle battery feeding the input to the boost converter and the boost converter’s output feeding the inputs to the buck converters. This allows the two buck outputs to maintain regulation whether the battery is above or below the buck outputs. The outputs can stay regulated through the entire input range presented by the vehicle battery, handling transients as low as 2.5V during engine restart or cold crank and transients as high as 38V during load dump.

## THINK OF IT AS A DUAL BUCK-BOOST

In this configuration, the LTC3859 can be thought of as a dual output buck-boost controller, in that it produces two regulated outputs that can be above or below the input voltage. When the input is low, the boost converter operates and steps up the voltage to an intermediate rail that provides enough headroom for the buck converters to operate. When the input voltage is high enough, the boost converter stops switching

and simply turns on the top switch to pass the input voltage through to the intermediate rail to feed the bucks.

## BOOST CONTROLLER

The LTC3859’s boost controller is based on Linear Technology’s new LTC3788/LTC3787/LTC3786 family of high voltage, constant frequency, current-mode synchronous boost controllers that drive all N-channel MOSFET power stages. It can boost to output voltages as high as 60V from a 4.5V to 38V (40V abs max) input voltage. If the LTC3859 is biased from  $V_{OUT}$  or another supply, the boost converter can operate from an input voltage as low as 2.5V after start-up. Synchronous rectification eliminates both the high power loss in the catch diode and the need for a heat sink at high output currents. Strong internal gate drivers reduce switching losses at high output voltages.

The control architecture senses current at the input supply using a sense resistor in series with the inductor (or by using inductor DCR sensing). The inductor current is constantly monitored and no blanking is required, enabling it to achieve very low bottom MOSFET duty cycles with a very small 110ns minimum on-time.

Figure 1. Typical automotive application using the LTC3859

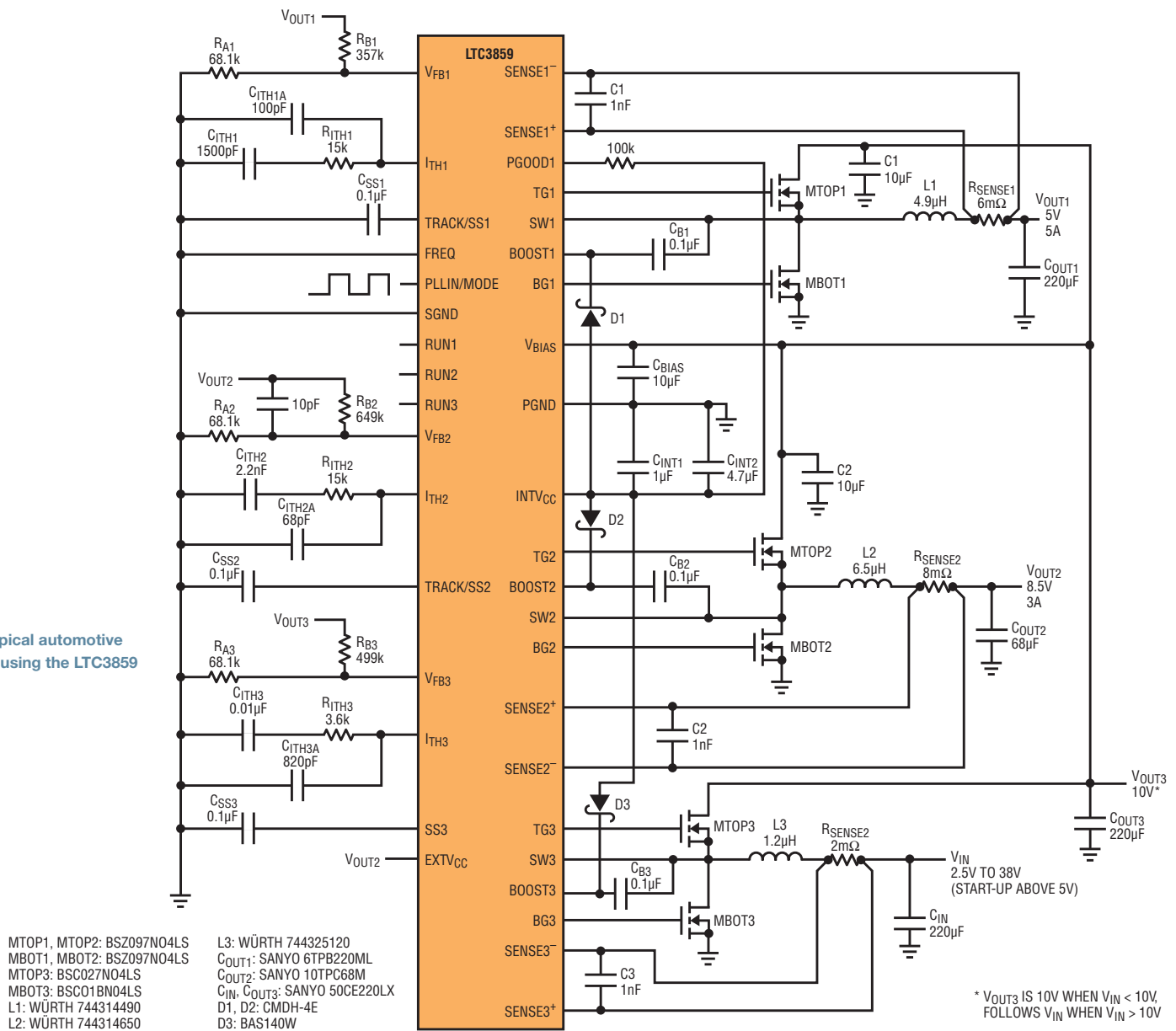

In a boost converter, the duty cycle gets smaller as the input voltage approaches the programmed output voltage and equals 0% when  $v_{IN} = v_{OUT}$ . Traditional non-synchronous boost controllers that sense the bottom FET current do not smoothly handle the transition as  $v_{IN}$  approaches the programmed  $v_{OUT}$ , often having excessive, unpredictable, low frequency ripple that begins when the minimum on-time is reached. Most of those controllers have relatively long minimum on-times (often greater than 200ns), which means that high ripple can occur over a relatively wide band of input voltages.

In contrast, the LTC3859 boost controller gracefully handles the transition as  $v_{IN}$  moves up or down through the programmed output voltage without creating excessive ripple. Because of the small minimum on-time, constant frequency operation is maintained until  $v_{IN}$  is just below  $v_{OUT}$ , at which point the part skips bottom FET on cycles as needed until it is off continuously (0% duty cycle) and the synchronous top FET is on continuously (100% duty cycle). Unlike most boost converters, the LTC3859's ripple during this transition region is substantially smaller than it is at lower  $v_{IN}$  during “normal” boosting.

The LTC3859 is able to keep the synchronous MOSFET on continuously by integrating a small charge pump inside its driver. This charge pump maintains the voltage on the bootstrap capacitor that serves as the floating supply (BOOST3-SW3 voltage) for the top driver. Otherwise, the voltage on this capacitor might decay due to board or diode leakage current.

### DUAL BUCK CONTROLLERS

Along with the single boost controller, the LTC3859 also integrates a pair of synchronous buck (step-down) controllers based on the LTC3857/58 family of low quiescent buck controllers. They

drive all N-channel MOSFETs and feature a precision 0.8V reference. They accept inputs up to 38V (40V abs max) and the outputs can be programmed between 0.8V to 24V (28V abs max). The 95ns minimum on-time allows high frequency operation at low duty cycles.

## OTHER FEATURES

The LTC3859 shares many of the same popular features of the LTC3788 and LTC3857 families on which it was based. The MOSFET drivers and control circuits are powered by INTV<sub>CC</sub>, which by default is generated from an internal low dropout (LDO) regulator from the main bias supply pin (V<sub>BIAS</sub>). To reduce power dissipation due to MOSFET gate charge losses and improve efficiency, a supply between 5V and 14V (abs max) may be connected to the EXTV<sub>CC</sub> pin. When a supply is detected on EXTV<sub>CC</sub>, the V<sub>BIAS</sub> LDO is disabled and another LDO between EXTV<sub>CC</sub> and INTV<sub>CC</sub> is enabled. EXTV<sub>CC</sub> is commonly connected to one of the output voltages generated by the buck controllers.

The switching frequency can be programmed between 50kHz and 900kHz using the FREQ pin, or synchronized via the PLLIN/MODE pin to an external clock between 75kHz and 850kHz using an integrated phase-locked loop. The buck controllers (channels 1 and 2) operate 180° out-of-phase to minimize the capacitance required on their

input. The boost controller (channel 3) operates in phase with channel 1.

All outputs have independent enable (RUN<sub>1,2,3</sub>) and soft-start (TRACK/SS<sub>1,2</sub> and SS<sub>3</sub> pins). The TRACK/SS pins on the buck controllers can also be used to track other supplies during start-up. The PGOOD<sub>1</sub> and OV<sub>3</sub> are open-drain pins that respectively indicate whether buck channel 1 is in regulation and whether the boost channel is in overvoltage (V<sub>IN</sub> > programmed V<sub>OUT</sub> + 10%). Protection features include short-circuit and overvoltage protection for the bucks and overtemperature protection. At light loads, the user can select from three modes of operation—Burst Mode operation, pulse-skipping mode, or forced continuous mode—using the PLLIN/MODE pin.

## LOW I<sub>Q</sub> FOR ALWAYS-ON SYSTEMS

When Burst Mode operation is selected, the LTC3859 features an ultralow operating quiescent current (55μA with one buck on, 65μA with one buck and the boost on, or 80μA with all three channels on). This makes the LTC3859 ideal for always-on systems, where one or more outputs are always enabled and low quiescent current is required to extend run-times and preserve battery life. Automobiles have an increasing number of these systems (regardless of whether they also have start-stop systems) that remain on even when the vehicle is parked for days or weeks. Examples of

these include telematics systems, anti-theft systems, and keyless-entry systems.

## 5V AND 8.5V OUTPUTS FROM AUTOMOTIVE BATTERY, EVEN DURING COLD CRANK

Figure 1 shows a highly integrated solution that utilizes the unique features of the LTC3859 to efficiently solve the design challenges associated with automotive start-stop and always-on systems. In this circuit, the boost controller input is connected directly to the car battery, and the boost output, which is programmed to 10V, serves as the input to the two buck controllers, which generate the 5V and 8.5V outputs. The 5V supply might typically be used to power an always-on system and the 8.5V supply for a DVD player.

The LTC3859 V<sub>BIAS</sub> pin is powered from the output of the boost converter. The EXTV<sub>CC</sub> pin is connected to the 8.5V (or alternatively the 5V supply) to improve efficiency, particularly at high battery voltage.

Normally, the battery sits around 12V–14V, so the input to the boost converter is higher than its programmed 10V output. Under these conditions, the control loop forces the top MOSFET on continuously. The internal charge pump maintains the supply voltage (BOOST<sub>3</sub>-SW<sub>3</sub>) for the top MOSFET driver (TG<sub>3</sub> to ensure 100% duty cycle operation). With the top MOSFET on continuously, the boost converter simply passes the battery voltage directly through to the buck inputs, minimizing power loss.

During engine start-up, when the battery voltage can dip to 5V or lower, the boost converter starts switching when the battery voltage drops below 10V and keeps the buck inputs pinned at 10V. This prevents the buck converters from ever going into dropout, allowing the bucks to maintain output regulation at 5V and 8.5V although the car battery can fall below these voltages. The LTC3859 boost controller's very low 2.5V input common mode range allows for a regulated

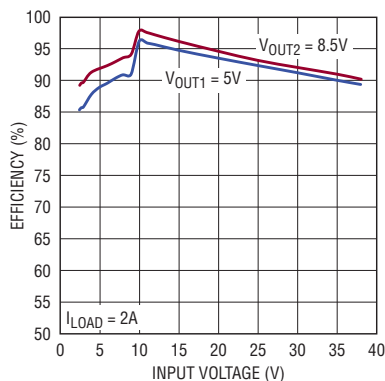

Figure 2. Efficiency vs input voltage for Figure 1.

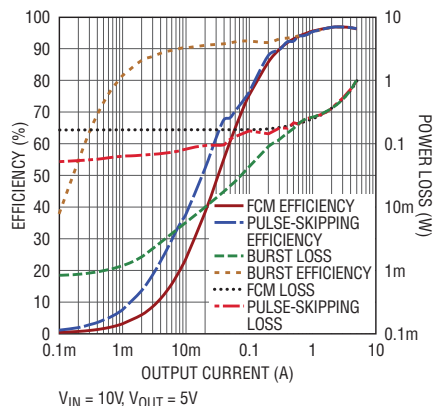

Figure 3. Efficiency and power loss vs load current of 5V output for Figure 1.

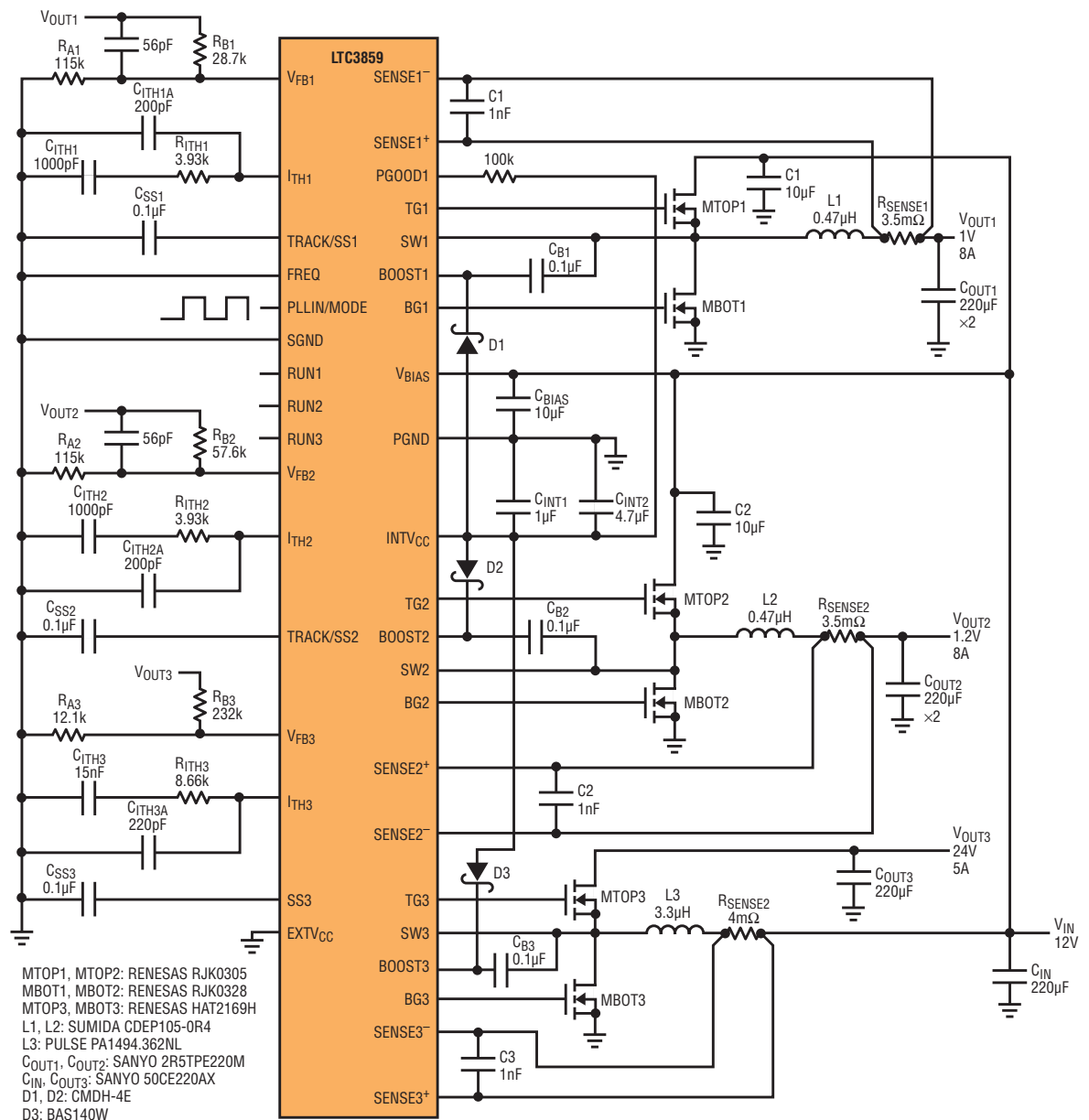

Figure 4. General purpose triple output application using the LTC3859

boost output voltage, and thus stable buck output voltages, even through some of the harshest cold crank transients.

Figure 2 shows the total efficiency at 2A load with  $V_{IN}$  spanning from 2.5V to 38V. The low quiescent current allows the 5V supply to remain on at all times without significantly deteriorating the vehicle battery life. Figure 3 shows the efficiency and power loss of the 5V output over a broad load range.

### GENERAL PURPOSE TRIPLE OUTPUT CONTROLLER

As impressive as the LTC3859 is in these dual buck-boost applications, it of course can also be configured as a simple triple output converter. Figure 4 shows a circuit generating 24V, 1V and 1.2V outputs from a 12V input.

### CONCLUSION

The LTC3859 is a low  $I_Q$  triple output controller that offers a compelling, compact solution to the demanding design

challenges in modern automotive electronics. Configuring the synchronous boost controller in front of the two synchronous buck controllers provides dual supply voltages that maintain regulation over the entire voltage range of the car battery. This makes the LTC3859 ideal for high efficiency power conversion in always-on and start-stop systems. The LTC3859 packs all of this and more into small, thermally enhanced 38-pin 5mm × 7mm QFN or 38-lead TSSOP packages. ■